

NAFLIC

National Association For Leisure Industry Certification

Standards & Related Documents Committee

TECHNICAL BULLETIN — June 2016

403. Hoerbiger hydraulic cylinders

Following the issuing of TB 383 on this subject, NAFLIC is now in receipt of further advice relating to Hoerbiger hydraulic cylinders, as per the attached service bulletin received from Vekoma. This is further advice on these items.

The information contained within is that of the manufacturer and not NAFLIC. When following the advice from the manufacturer, you are reminded of your duties and responsibilities under HSG175 regarding modifications.

Committee Members: Mr. D Dadswell (Chairman), Mr. A Mellor (Secretary), Mr. P Smith, Mr. J Green,
Mr. D Cox, Mr. M Thirkettle, Mr. I Davies, Mr. J Shilling & Mr. D Inman



Issuing Entity:	Bulletin No.: SB-033_02
Vekoma Rides Parts & Services B.V.	Release Date: 16-03-2016
Schaapweg 18	Effective Date: immediately
6063 BA VLODROP	Supersedes: SB-033_01
The Netherlands	Completion Date: 01-01-2017
CoC Number: 12049585	

Service Bulletin

Original Ride Manufacturer: Table 1	Affected Production Dates: All
Ride Name: Various	Affected Serial Nos: Table 1
Model No: Various	

Abstract of issue:

Action required in relation to attention items as described by Hoerbiger Micro Fluid GmbH.

Reason for release:

The release of safety related document of Hoerbiger Micro Fluid GmbH about hydraulic locking units.

Action to be taken:

Each customer should take notice of the risk categories, as described on page 9. Depending on the risk category different actions has to be taken. Chapter 1 untill 2.3 are identical to SB-033_12012015_Rev00, this bulletin provides updated information starting in chapter 2.4.

Date	Revision date	Comment
01-2015	00	Initial version
03-2015	01	Updated information in regard 1050 cycle test
03-2016	02	Official statement regarding lifetime HLU's is added

* In the interests of safety and as a service to the industry, Vekoma Rides Parts & Services B.V. issues technical information bulletins for the benefit of owners of amusement rides that are manufactured by Vekoma Rides Manufacturing B.V. (both companies are members of the Vekoma Rides B.V.). These bulletins may also contain technical information, on parts or modifications relating to amusement rides, manufactured by *Vekoma International B.V.* and / or *Vekoma Manufacturing B.V.* These are dissolved companies which have no legal relationship whatsoever with the Vekoma Rides B.V.

Vekoma Rides B.V. including its affiliated companies, agents and employees make no warranties and assume no responsibility for any misapplication or misinterpretation of the information provided, ride down time, consequential damages, loss, injuries, causes of action, claims, demands and expenses (including legal fees), of any kind or nature, arising directly or indirectly, in whole or in part, from or in relation to this technical information bulletin; nor for any amusement ride equipment built by any manufacturer(s) other than Vekoma Rides Manufacturing B.V.

All information relating to amusement rides, parts or modifications built or carried out by manufacturers other than Vekoma Rides Manufacturing B.V. and/or marked with an asterisk "*" are recommendations only and are not to be considered in any way to be advisory or mandatory, relied upon, nor imply any obligations or liabilities whatsoever.

IB-nr.	Original Ride Manufacturer	Project number
10505	Vekoma Rides Manufacturing B.V. (train), Arrow (ride)*	91178
10507	Vekoma International B.V./ Vekoma Manufacturing B.V.* (train)	91028/29/30/31
27505	Vekoma International B.V./ Vekoma Manufacturing B.V.*	91685
27521	Vekoma International B.V./ Vekoma Manufacturing B.V.*	89605
27526	Vekoma International B.V./ Vekoma Manufacturing B.V.*	95115
27546	Vekoma Rides Manufacturing B.V.*	60022
27547	Vekoma Rides Manufacturing B.V.*	60392
27548	Vekoma Rides Manufacturing B.V.*	60393
27550	Vekoma Rides Manufacturing B.V.*	60542
27551	Vekoma Rides Manufacturing B.V.*	60543
27552	Vekoma Rides Manufacturing B.V.*	60559
27541	Vekoma International B.V./ Vekoma Manufacturing B.V.*	99269
29003	Vekoma International B.V./ Vekoma Manufacturing B.V.*	78830
29501	Vekoma International B.V./ Vekoma Manufacturing B.V.*	80880
29504	Vekoma International B.V./ Vekoma Manufacturing B.V.*	84535
32003	Vekoma International B.V./ Vekoma Manufacturing B.V.*	93137
32010	Vekoma International B.V./ Vekoma Manufacturing B.V.* (1 train)	94136
32012	Vekoma International B.V./ Vekoma Manufacturing B.V.*	96398
32041	Vekoma Rides Manufacturing B.V.*	60450
32042	Vekoma Rides Manufacturing B.V.*	60614
34501	Vekoma International B.V./ Vekoma Manufacturing B.V.*	86760
34502	Vekoma International B.V./ Vekoma Manufacturing B.V.*	86700
36501	Vekoma International B.V./ Vekoma Manufacturing B.V.*	20121
36502	Vekoma International B.V./ Vekoma Manufacturing B.V.*	20160
36503	Vekoma Rides Manufacturing B.V.*	91086
36504	Vekoma Rides Manufacturing B.V.*	91091
36505	Vekoma Rides Manufacturing B.V.*	91152
36506	Vekoma Rides Manufacturing B.V.*	60001
36507	Vekoma Rides Manufacturing B.V.*	60024

* In the interests of safety and as a service to the industry, Vekoma Rides Parts & Services B.V. issues technical information bulletins for the benefit of owners of amusement rides that are manufactured by Vekoma Rides Manufacturing B.V. (both companies are members of the Vekoma Rides B.V.). These bulletins may also contain technical information, on parts or modifications relating to amusement rides, manufactured by *Vekoma International B.V.* and / or *Vekoma Manufacturing B.V.* These are dissolved companies which have no legal relationship whatsoever with the Vekoma Rides B.V.

Vekoma Rides B.V. including its affiliated companies, agents and employees make no warranties and assume no responsibility for any misapplication or misinterpretation of the information provided, ride down time, consequential damages, loss, injuries, causes of action, claims, demands and expenses (including legal fees), of any kind or nature, arising directly or indirectly, in whole or in part, from or in relation to this technical information bulletin; nor for any amusement ride equipment built by any manufacturer(s) other than Vekoma Rides Manufacturing B.V.

All information relating to amusement rides, parts or modifications built or carried out by manufacturers other than Vekoma Rides Manufacturing B.V. and/or marked with an asterisk "*" are recommendations only and are not to be considered in any way to be advisory or mandatory, relied upon, nor imply any obligations or liabilities whatsoever.

IB-nr.	Original Ride Manufacturer	Project number
38058	Vekoma Rides Manufacturing B.V.*	60588
38059	Vekoma Rides Manufacturing B.V.*	60612
38501	Vekoma International B.V./ Vekoma Manufacturing B.V.*	94138
39505	Vekoma Rides Manufacturing B.V.*	91116
39509	Vekoma Rides Manufacturing B.V.*	90350
40008	Vekoma Rides Manufacturing B.V.*	60114
40009	Vekoma Rides Manufacturing B.V.*	60123
40010	Vekoma Rides Manufacturing B.V.*	60159
40011	Vekoma Rides Manufacturing B.V.*	60237
44501	Vekoma Rides Manufacturing B.V.*	60004/13
44502	Vekoma Rides Manufacturing B.V.*	60031
44503	Vekoma Rides Manufacturing B.V.*	60054
44504	Vekoma Rides Manufacturing B.V.*	60157
45001	Vekoma Rides Manufacturing B.V.*	60102
45002	Vekoma Rides Manufacturing B.V.*	60071
45003	Vekoma Rides Manufacturing B.V.*	60178
45004	Vekoma Rides Manufacturing B.V.*	60440
45005	Vekoma Rides Manufacturing B.V.*	60459
45007	Vekoma Rides Manufacturing B.V.*	60507
45009	Vekoma Rides Manufacturing B.V.*	60565
45011	Vekoma Rides Manufacturing B.V.*	60613
50501	Vekoma Rides Manufacturing B.V.*	60327
50502	Vekoma Rides Manufacturing B.V.*	60356
50504	Vekoma Rides Manufacturing B.V.*	60343
50505	Vekoma Rides Manufacturing B.V.*	60584
51001	Vekoma Rides Manufacturing B.V.*	60338
45501	Vekoma Rides Manufacturing B.V.*	60160
50001	Vekoma Rides Manufacturing B.V.*	60195
55001	Vekoma Rides Manufacturing B.V.*	60195

Table 1: Affected serial Nos.

* In the interests of safety and as a service to the industry, Vekoma Rides Parts & Services B.V. issues technical information bulletins for the benefit of owners of amusement rides that are manufactured by Vekoma Rides Manufacturing B.V. (both companies are members of the Vekoma Rides B.V.). These bulletins may also contain technical information, on parts or modifications relating to amusement rides, manufactured by *Vekoma International B.V.* and / or *Vekoma Manufacturing B.V.* These are dissolved companies which have no legal relationship whatsoever with the Vekoma Rides B.V.

Vekoma Rides B.V. including its affiliated companies, agents and employees make no warranties and assume no responsibility for any misapplication or misinterpretation of the information provided, ride down time, consequential damages, loss, injuries, causes of action, claims, demands and expenses (including legal fees), of any kind or nature, arising directly or indirectly, in whole or in part, from or in relation to this technical information bulletin; nor for any amusement ride equipment built by any manufacturer(s) other than Vekoma Rides Manufacturing B.V.

All information relating to amusement rides, parts or modifications built or carried out by manufacturers other than Vekoma Rides Manufacturing B.V. and/or marked with an asterisk "*" are recommendations only and are not to be considered in any way to be advisory or mandatory, relied upon, nor imply any obligations or liabilities whatsoever.



Issuing Entity:	Bulletin No.: SB-033_02
Vekoma Rides Parts & Services B.V.	Release Date: 16-03-2016
Schaapweg 18	Effective Date: immediately
6063 BA VLODRUP	Supersedes: SB-033_01
The Netherlands	Completion Date: 01-01-2017
CoC Number: 12049585	

Table of Contents 4

1 Introduction 5

2 Main points of attention 5

 2.1 Connection of the piston rod at joint head5

 2.2 Connection of the threaded screw assembly6

 2.3 Connection of the accumulator8

 2.4 Contaminated oil in the cylinder8

 2.5 Cycle testing11

 2.6 Spare parts in customer Warehouse13

 2.7 Lifetime HLU13

3 General remark 15

Appendix A: official statement Hoerbiger 16

* In the interests of safety and as a service to the industry, Vekoma Rides Parts & Services B.V. issues technical information bulletins for the benefit of owners of amusement rides that are manufactured by Vekoma Rides Manufacturing B.V. (both companies are members of the Vekoma Rides B.V.). These bulletins may also contain technical information, on parts or modifications relating to amusement rides, manufactured by *Vekoma International B.V.* and / or *Vekoma Manufacturing B.V.* These are dissolved companies which have no legal relationship whatsoever with the Vekoma Rides B.V.

Vekoma Rides B.V. including its affiliated companies, agents and employees make no warranties and assume no responsibility for any misapplication or misinterpretation of the information provided, ride down time, consequential damages, loss, injuries, causes of action, claims, demands and expenses (including legal fees), of any kind or nature, arising directly or indirectly, in whole or in part, from or in relation to this technical information bulletin; nor for any amusement ride equipment built by any manufacturer(s) other than Vekoma Rides Manufacturing B.V.

All information relating to amusement rides, parts or modifications built or carried out by manufacturers other than Vekoma Rides Manufacturing B.V. and/or marked with an asterisk "*" are recommendations only and are not to be considered in any way to be advisory or mandatory, relied upon, nor imply any obligations or liabilities whatsoever.

1 Introduction

Through Hoerbiger Micro Fluid GmbH (hereafter referred to as “Supplier”) we received a safety related document that gives information about mainly 3 possible issues with their hydraulic locking units (hereafter referred to as “HLU”) which are manufactured before June 2014.

After reviewing the information from the Supplier, VRP&S would like to share the advice given by Supplier. In chapter 2 these items as well as an additional clarification are further illustrated and VRP&S’ advice is included for both the LE 25 and LE 32 HLU’s.

2 Main points of attention

The Supplier document mainly describes 3 points of attention on which they propose to take action, with the additional clarification of VRP&S (item 3) the following 4 items are mentioned:

1. Connection of the piston rod at joint head
2. Connection of the threaded screw assembly
3. Connection of the accumulator
4. Contaminated oil in the HLU

In the next paragraphs you will find more information and advice.

2.1 Connection of the piston rod at joint head

Issue	: In the past the Supplier could not guarantee that the piston rod could not come loose at the joint head.
Action Supplier	: With the newly delivered HLU’s, the production process was changed by adding Loctite 243, a locknut and torque striping. This way they are able to guarantee that the piston rod can not come loose at the joint head.
VRP&S’ advice	: Add torque striping to the piston rod at the joint head (see figure 1) and perform a weekly check on this area. HLU’s that are not installed yet (such as spare cylinders) need to be checked for Loctite 243 before installation. See the remarks next to Table 2 for the correct torque values of the rod ends for both the LE 25 and LE 32 units.

Note: *in case of old configuration HLU (without locknut).*

Apply Loctite 270 and torque striping. In case no locknut is applied, the torque values for the LE 25 and LE 32 unit are respectively 25 ±5Nm and 30 +5Nm.

* In the interests of safety and as a service to the industry, Vekoma Rides Parts & Services B.V. issues technical information bulletins for the benefit of owners of amusement rides that are manufactured by Vekoma Rides Manufacturing B.V. (both companies are members of the Vekoma Rides B.V.). These bulletins may also contain technical information, on parts or modifications relating to amusement rides, manufactured by *Vekoma International B.V.* and / or *Vekoma Manufacturing B.V.* These are dissolved companies which have no legal relationship whatsoever with the Vekoma Rides B.V.

Vekoma Rides B.V. including its affiliated companies, agents and employees make no warranties and assume no responsibility for any misapplication or misinterpretation of the information provided, ride down time, consequential damages, loss, injuries, causes of action, claims, demands and expenses (including legal fees), of any kind or nature, arising directly or indirectly, in whole or in part, from or in relation to this technical information bulletin; nor for any amusement ride equipment built by any manufacturer(s) other than Vekoma Rides Manufacturing B.V.

All information relating to amusement rides, parts or modifications built or carried out by manufacturers other than Vekoma Rides Manufacturing B.V. and/or marked with an asterisk “*” are recommendations only and are not to be considered in any way to be advisory or mandatory, relied upon, nor imply any obligations or liabilities whatsoever.



Figure 1: how to apply torque striping on the rod end.

2.2 Connection of the threaded screw assembly

- Issue** : The supplier added an additional requirement on the length of the threaded screw assembly. Due to the adjustment function of this connection it is not guaranteed that the threaded screw assembly is within the specified range.
- Action VRP&S'** : Checking this connection was included during installation of the HLU in the vehicle.
- VRP&S' advice** : Check the length of the threaded screw assembly. If applicable it needs to be corrected. For the correct settings, please refer to the text below for the LE32 units and table 2 for the LE25 units (these values are created from the Supplier's document). Add torque striping to the connection (see figure 2) and perform a weekly check on this area.

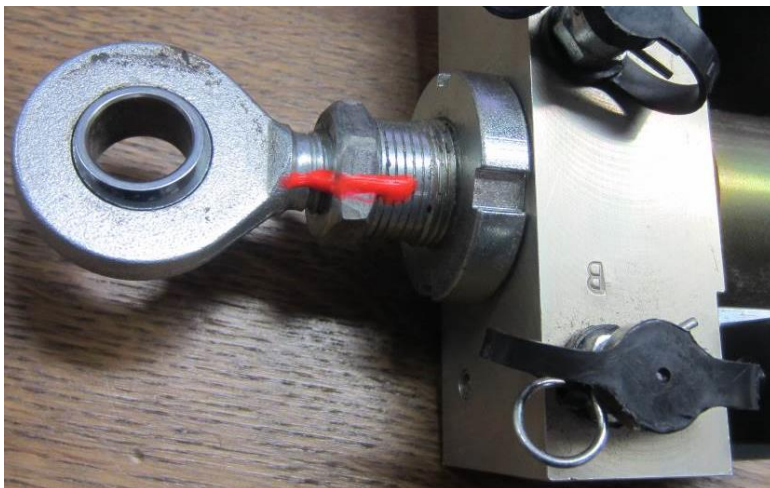

Figure 2: how to apply torque striping on the threaded screw assembly at the bottom.

* In the interests of safety and as a service to the industry, Vekoma Rides Parts & Services B.V. issues technical information bulletins for the benefit of owners of amusement rides that are manufactured by Vekoma Rides Manufacturing B.V. (both companies are members of the Vekoma Rides B.V.). These bulletins may also contain technical information, on parts or modifications relating to amusement rides, manufactured by *Vekoma International B.V.* and / or *Vekoma Manufacturing B.V.* These are dissolved companies which have no legal relationship whatsoever with the Vekoma Rides B.V.

Vekoma Rides B.V. including its affiliated companies, agents and employees make no warranties and assume no responsibility for any misapplication or misinterpretation of the information provided, ride down time, consequential damages, loss, injuries, causes of action, claims, demands and expenses (including legal fees), of any kind or nature, arising directly or indirectly, in whole or in part, from or in relation to this technical information bulletin; nor for any amusement ride equipment built by any manufacturer(s) other than Vekoma Rides Manufacturing B.V.

All information relating to amusement rides, parts or modifications built or carried out by manufacturers other than Vekoma Rides Manufacturing B.V. and/or marked with an asterisk "*" are recommendations only and are not to be considered in any way to be advisory or mandatory, relied upon, nor imply any obligations or liabilities whatsoever.

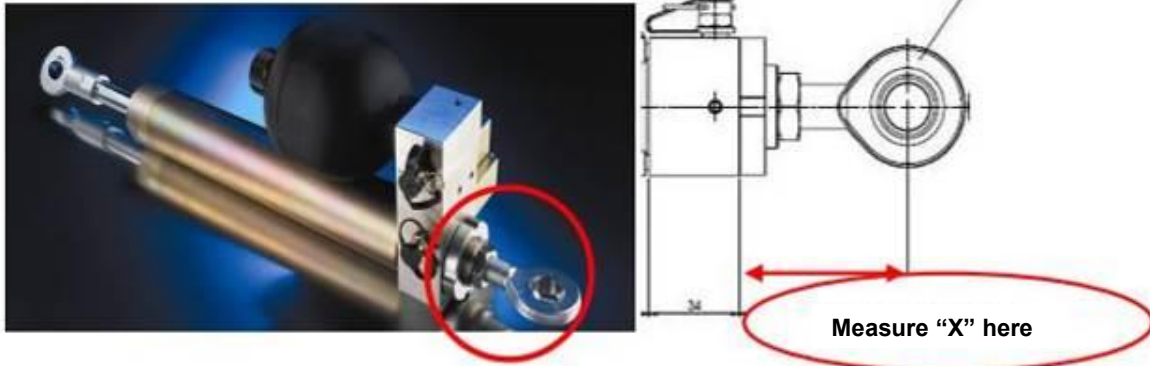

Figure 3: information for LE32 and LE25 screw connection at the bottom.

The following data apply for all LE32 versions:

For the LE 32 versions the screw thread depth is correct when the rod end length “X” is below 65 mm. ($X < 65\text{mm}$)

The following data apply for all LE25 versions:

For the LE 25 versions the screw thread depth is correct if the rod end length “X” is below the value as stated behind the product number in de table below. The small x at the end of the product number indicates the version number.

Product number	Maximum screw thread depth “X”	
850-7001-x	68	Mm
850-7002-x	68	Mm
850-7003-x	68	Mm
850-7004-x	68	Mm
850-7010-x	68	Mm
850-7013-x	65.5	Mm
850-7015-x	68	Mm
850-7016-x	68	Mm
850-7018-x	68	Mm
850-7019-x	68	Mm
850-7020-x	63.25	Mm
850-7021-x	63.25	Mm
850-8002-x	66	Mm
850-8003-x	66	Mm
850-8007-x	65.5	Mm
850-8008-x	68.25	Mm
850-8009-x	68.25	Mm

We strongly urge you to immediately check the measurement set out above on all Personal Restraint Systems in your possession and advise your technicians to adjust and maintain the measurements specified when installing the unit into a Personal Restraint System or during routine maintenance.

We recommend that the joint rod heads be secured at the specified dimensions and tightened with a torque wrench. The LE 25 version should be tightened to **80 Nm ±10 Nm**. The LE 32 version should be tightened to **90 Nm ±10 Nm**.

The correct measurement must be set and checked when installing or performing maintenance on the Cylinder Accumulator unit. In this way the required minimum screw thread depth engagement (as set out in VDI 2230) is maintained.

Table 2: LE25 screw connection lengths at the bottom and additional text box from Supplier’s document.

* In the interests of safety and as a service to the industry, Vekoma Rides Parts & Services B.V. issues technical information bulletins for the benefit of owners of amusement rides that are manufactured by Vekoma Rides Manufacturing B.V. (both companies are members of the Vekoma Rides B.V.). These bulletins may also contain technical information, on parts or modifications relating to amusement rides, manufactured by *Vekoma International B.V.* and / or *Vekoma Manufacturing B.V.* These are dissolved companies which have no legal relationship whatsoever with the Vekoma Rides B.V.

Vekoma Rides B.V. including its affiliated companies, agents and employees make no warranties and assume no responsibility for any misapplication or misinterpretation of the information provided, ride down time, consequential damages, loss, injuries, causes of action, claims, demands and expenses (including legal fees), of any kind or nature, arising directly or indirectly, in whole or in part, from or in relation to this technical information bulletin; nor for any amusement ride equipment built by any manufacturer(s) other than Vekoma Rides Manufacturing B.V.

All information relating to amusement rides, parts or modifications built or carried out by manufacturers other than Vekoma Rides Manufacturing B.V. and/or marked with an asterisk “*” are recommendations only and are not to be considered in any way to be advisory or mandatory, relied upon, nor imply any obligations or liabilities whatsoever.

2.3 Connection of the accumulator

- Issue** : After reviewing all connections and the Hoerbiger safety related document, below actions are taken to reduce the risk of a loosening accumulator.
- Action Supplier** : Checking the accumulator connection was included in the assembly process.
- VRP&S' advice** : Add torque striping between the connection of the accumulator and the manifold block (see figure 4) and perform a weekly check on this section.



Figure 4: how to apply torque striping on the accumulator.

2.4 Contaminated oil in the cylinder

- Issue** : During assembly of the cylinder the Supplier could not guarantee that small particles would not get stuck in the valve. This could affect the functionality of the HLU.
- Action Supplier** : The Supplier changed the production process by using an improved flushing system for the manifold blocks.
Besides that, they added a 1050 cycle test for all new manufactured HLU's, to convince themselves the HLU is not contaminated.
- VRP&S' advice** : For all HLU's in the field it is our advice to clearly instruct your operators to follow the instruction in the Owner's Manual: always check that the restraint is being closed as tightly as possible to the passenger's body. All restraints must be checked manually by pulling to see if they remain closed. Always check the restraint for locking before dispatch.
For all cylinders that are kept in stock: please return them to our facilities for general inspection and cycle test.

* In the interests of safety and as a service to the industry, Vekoma Rides Parts & Services B.V. issues technical information bulletins for the benefit of owners of amusement rides that are manufactured by Vekoma Rides Manufacturing B.V. (both companies are members of the Vekoma Rides B.V.). These bulletins may also contain technical information, on parts or modifications relating to amusement rides, manufactured by *Vekoma International B.V.* and / or *Vekoma Manufacturing B.V.* These are dissolved companies which have no legal relationship whatsoever with the Vekoma Rides B.V.

Vekoma Rides B.V. including its affiliated companies, agents and employees make no warranties and assume no responsibility for any misapplication or misinterpretation of the information provided, ride down time, consequential damages, loss, injuries, causes of action, claims, demands and expenses (including legal fees), of any kind or nature, arising directly or indirectly, in whole or in part, from or in relation to this technical information bulletin; nor for any amusement ride equipment built by any manufacturer(s) other than Vekoma Rides Manufacturing B.V.

All information relating to amusement rides, parts or modifications built or carried out by manufacturers other than Vekoma Rides Manufacturing B.V. and/or marked with an asterisk "*" are recommendations only and are not to be considered in any way to be advisory or mandatory, relied upon, nor imply any obligations or liabilities whatsoever.



Issuing Entity:	Bulletin No.: SB-033_02
Vekoma Rides Parts & Services B.V.	Release Date: 16-03-2016
Schaapweg 18	Effective Date: immediately
6063 BA VLODROP	Supersedes: SB-033_01
The Netherlands	Completion Date: 01-01-2017
CoC Number: 12049585	

Additional Requirements per release of this Bulletin:

Based on new information which was provided by Hoerbiger VRP&S needs to redraw the statement partially that no additional action is required for the HLU's which are installed on operating vehicles. New information received by Vekoma from Hoerbiger shows a reduced level of confidence with regard to safe operation of the HLU.

While looking to our fleet of vehicles we can divide our fleet in 3 risk categories:

Category A: vehicles which are equipped with HLU which already passed the 1050 cycles test performed by Hoerbiger.

Category B: vehicles which are at lower potential risk, these vehicles are equipped with a category 3 restraint according to EN13814.

Category C: vehicles at higher potential risk, these vehicles are equipped with a category 4 or 5 restraint according to EN 13814.

In this Bulletin we clearly like to indicate the required actions for each category:

- **Category A: HLU which passed 1050 cycle test.**

No additional tests are required for the HLU's which passed the 1050 cycle test successfully. A check has to be performed to ensure that the HLU's that are installed on the ride vehicles are marked with "Passed 1050 Test"

Table 2 (hereunder), shows all vehicles which are equipped with HLU which already passed 1050 cycle test.

IB-nr.	Original Ride Manufacturer	Project number
38058	Vekoma Rides Manufacturing B.V.*	60588
44507	Vekoma Rides Manufacturing B.V.*	60386
50505	Vekoma Rides Manufacturing B.V.*	60584
50001	Vekoma Rides Manufacturing B.V.*	60195
55001	Vekoma Rides Manufacturing B.V.*	60195

Table 2: Affected serial Nos.

* In the interests of safety and as a service to the industry, Vekoma Rides Parts & Services B.V. issues technical information bulletins for the benefit of owners of amusement rides that are manufactured by Vekoma Rides Manufacturing B.V. (both companies are members of the Vekoma Rides B.V.). These bulletins may also contain technical information, on parts or modifications relating to amusement rides, manufactured by *Vekoma International B.V.* and / or *Vekoma Manufacturing B.V.* These are dissolved companies which have no legal relationship whatsoever with the Vekoma Rides B.V.

Vekoma Rides B.V. including its affiliated companies, agents and employees make no warranties and assume no responsibility for any misapplication or misinterpretation of the information provided, ride down time, consequential damages, loss, injuries, causes of action, claims, demands and expenses (including legal fees), of any kind or nature, arising directly or indirectly, in whole or in part, from or in relation to this technical information bulletin; nor for any amusement ride equipment built by any manufacturer(s) other than Vekoma Rides Manufacturing B.V.

All information relating to amusement rides, parts or modifications built or carried out by manufacturers other than Vekoma Rides Manufacturing B.V. and/or marked with an asterisk "*" are recommendations only and are not to be considered in any way to be advisory or mandatory, relied upon, nor imply any obligations or liabilities whatsoever.

- **Category B: vehicles with lower potential risk.**

To ensure a certain level of safety, prior to the operation of the vehicles with guests we advise to perform the 1050 cycle test in two steps:

Step 1: Start cycle testing until 200 cycles are performed, like written in Chapter 2.5;

Step 2: Continue cycle testing until 1050 cycles are reached.

Table 3 shows all Category B vehicles.

IB-nr.	Original Ride Manufacturer	Project number
10507	Vekoma International B.V./ Vekoma Manufacturing B.V.* (train)	91028/29/30/31
34501	Vekoma International B.V./ Vekoma Manufacturing B.V.*	86760
34502	Vekoma International B.V./ Vekoma Manufacturing B.V.*	86700
36501	Vekoma International B.V./ Vekoma Manufacturing B.V.*	20121
36502	Vekoma International B.V./ Vekoma Manufacturing B.V.*	20160
36503	Vekoma Rides Manufacturing B.V.*	91086
36504	Vekoma Rides Manufacturing B.V.*	91091
36505	Vekoma Rides Manufacturing B.V.*	91152
36506	Vekoma Rides Manufacturing B.V.*	60001
36507	Vekoma Rides Manufacturing B.V.*	60024
38501	Vekoma International B.V./ Vekoma Manufacturing B.V.*	94138
39505	Vekoma Rides Manufacturing B.V.*	91116
39509	Vekoma Rides Manufacturing B.V.*	90350
39510	Vekoma Rides Manufacturing B.V.*	60428
40008	Vekoma Rides Manufacturing B.V.*	60114
40009	Vekoma Rides Manufacturing B.V.*	60123
40010	Vekoma Rides Manufacturing B.V.*	60159
40011	Vekoma Rides Manufacturing B.V.*	60237
45001	Vekoma Rides Manufacturing B.V.*	60102
45002	Vekoma Rides Manufacturing B.V.*	60071
45003	Vekoma Rides Manufacturing B.V.*	60178

* In the interests of safety and as a service to the industry, Vekoma Rides Parts & Services B.V. issues technical information bulletins for the benefit of owners of amusement rides that are manufactured by Vekoma Rides Manufacturing B.V. (both companies are members of the Vekoma Rides B.V.). These bulletins may also contain technical information, on parts or modifications relating to amusement rides, manufactured by *Vekoma International B.V.* and / or *Vekoma Manufacturing B.V.* These are dissolved companies which have no legal relationship whatsoever with the Vekoma Rides B.V.

Vekoma Rides B.V. including its affiliated companies, agents and employees make no warranties and assume no responsibility for any misapplication or misinterpretation of the information provided, ride down time, consequential damages, loss, injuries, causes of action, claims, demands and expenses (including legal fees), of any kind or nature, arising directly or indirectly, in whole or in part, from or in relation to this technical information bulletin; nor for any amusement ride equipment built by any manufacturer(s) other than Vekoma Rides Manufacturing B.V.

All information relating to amusement rides, parts or modifications built or carried out by manufacturers other than Vekoma Rides Manufacturing B.V. and/or marked with an asterisk "*" are recommendations only and are not to be considered in any way to be advisory or mandatory, relied upon, nor imply any obligations or liabilities whatsoever.

IB-nr.	Original Ride Manufacturer	Project number
45004	Vekoma Rides Manufacturing B.V.*	60440
45005	Vekoma Rides Manufacturing B.V.*	60459
45007	Vekoma Rides Manufacturing B.V.*	60507
45008	Vekoma Rides Manufacturing B.V.*	60523
45009	Vekoma Rides Manufacturing B.V.*	60565
50501	Vekoma Rides Manufacturing B.V.*	60327
50502	Vekoma Rides Manufacturing B.V.*	60356
50504	Vekoma Rides Manufacturing B.V.*	60343
51001	Vekoma Rides Manufacturing B.V.*	60338
45501	Vekoma Rides Manufacturing B.V.*	60160

Table 3: Affected serial Nos.

2.5 Cycle testing

The cycle test is a test which provides information about the functionality of the HLU and the scale of the contaminations. The cycles test has to be performed 1050 times. After completion of 200 cycles succesfully, the ride can be taken into operation with passengers.

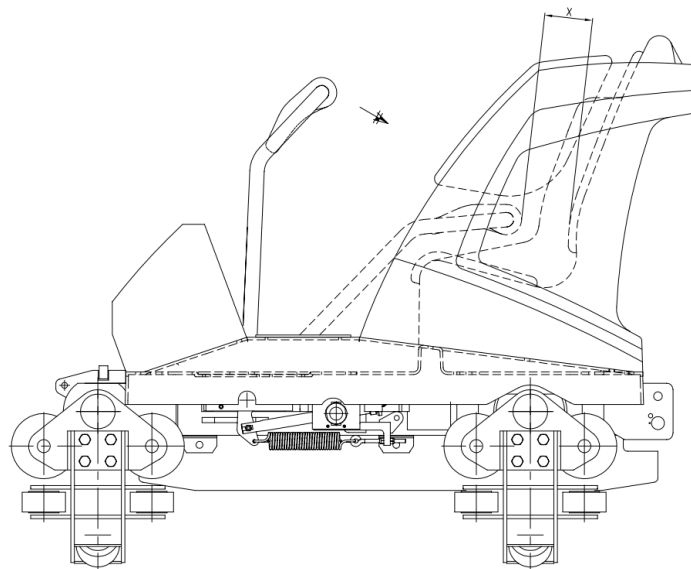

This example image is for reference of dimension X only.

* In the interests of safety and as a service to the industry, Vekoma Rides Parts & Services B.V. issues technical information bulletins for the benefit of owners of amusement rides that are manufactured by Vekoma Rides Manufacturing B.V. (both companies are members of the Vekoma Rides B.V.). These bulletins may also contain technical information, on parts or modifications relating to amusement rides, manufactured by *Vekoma International B.V.* and / or *Vekoma Manufacturing B.V.* These are dissolved companies which have no legal relationship whatsoever with the Vekoma Rides B.V.

Vekoma Rides B.V. including its affiliated companies, agents and employees make no warranties and assume no responsibility for any misapplication or misinterpretation of the information provided, ride down time, consequential damages, loss, injuries, causes of action, claims, demands and expenses (including legal fees), of any kind or nature, arising directly or indirectly, in whole or in part, from or in relation to this technical information bulletin; nor for any amusement ride equipment built by any manufacturer(s) other than Vekoma Rides Manufacturing B.V.

All information relating to amusement rides, parts or modifications built or carried out by manufacturers other than Vekoma Rides Manufacturing B.V. and/or marked with an asterisk "*" are recommendations only and are not to be considered in any way to be advisory or mandatory, relied upon, nor imply any obligations or liabilities whatsoever.

Warning



The test needs to be carried out before riding with guests.

The test can be performed while the HLU is installed.

Test procedure, **restraint with 2 HLU's**;

1. Close the restraint, make sure the right hand side HLU is only locking the restraint;
2. Measure the minimal distance (X) between the restraint and the seat (only at start of test);
3. Log this dimension for every seat (only at start of the test);
4. Wait for 10 seconds;
5. Measure the minimal distance (X) between the restraint and the seat;
6. In case this dimension increased by 2 cm the HLU failed and needs to be replaced immediately by a HLU which passed the 1050 cycles;
7. If no dimension change was noticed proceed with step 1;
8. Keep repeating this procedure until 200 cycles have passed the test procedure;
9. Repeat this test and make sure the left hand side HLU is only locking the restraint;
10. After completion of the 200 cycle test for the left and the right HLU it is allowed to take the vehicle in operation.

Warning



The test needs to be carried out before riding with guests.

The test can be performed while the HLU is installed.

Test procedure, **restraint with 1 HLU**;

1. Close the restraint
2. Measure the minimal distance (X) between the restraint and the seat (only at start of test);
3. Log this dimension for every seat (only at start of the test);
4. Wait for 10 seconds;
5. Measure the minimal distance (X) between the restraint and the seat;
6. In case this dimension increased by 2 cm the HLU failed and needs to be replaced immediately by a HLU which passed the 1050 cycles;
7. If no dimension change was noticed proceed with step 1;
8. Keep repeating this procedure until 200 cycles have passed the test procedure;
9. After completion of the 200 cycle test for the single HLU it is allowed to take the vehicle in operation.

Keep track of HLU's that did not pass the test and return them to VRP&S.

After completion of the 200 cycles, continue this test until you have reached 1050 cycles within 4 weeks after release of this Service Bulletin.

* In the interests of safety and as a service to the industry, Vekoma Rides Parts & Services B.V. issues technical information bulletins for the benefit of owners of amusement rides that are manufactured by Vekoma Rides Manufacturing B.V. (both companies are members of the Vekoma Rides B.V.). These bulletins may also contain technical information, on parts or modifications relating to amusement rides, manufactured by *Vekoma International B.V.* and / or *Vekoma Manufacturing B.V.* These are dissolved companies which have no legal relationship whatsoever with the Vekoma Rides B.V.

Vekoma Rides B.V. including its affiliated companies, agents and employees make no warranties and assume no responsibility for any misapplication or misinterpretation of the information provided, ride down time, consequential damages, loss, injuries, causes of action, claims, demands and expenses (including legal fees), of any kind or nature, arising directly or indirectly, in whole or in part, from or in relation to this technical information bulletin; nor for any amusement ride equipment built by any manufacturer(s) other than Vekoma Rides Manufacturing B.V.

All information relating to amusement rides, parts or modifications built or carried out by manufacturers other than Vekoma Rides Manufacturing B.V. and/or marked with an asterisk "*" are recommendations only and are not to be considered in any way to be advisory or mandatory, relied upon, nor imply any obligations or liabilities whatsoever.

- **Category C: vehicles with higher potential risk.**

All customers with vehicles in Category C will be informed by a separate Service Bulletin, namely SB-038_00.

2.6 Spare parts in customer Warehouse

All HLU's, at the customer warehouse should be checked if they are labelled with "passed 1050 cycle test". If this is not the case, contact VRP&S to make sure the HLU's will be tested prior to assembly into a vehicle. The picture below shows the correct indication that the HLU has passed the 1050 Cycle test.



2.7 Lifetime HLU

Hoerbiger has released an official statement regarding the lifetime of the HLU's (LE systems). Starting from delivery, LE systems must be replaced with new LE systems within **7 years**.

The two figures below explain the engraved data and the sticker data on the HLU's. All HLU's manufactured before June 2015 are equipped with a sticker and all HLU's manufactured from June 2015 and beyond are engraved.

The official Hoerbiger statement with all additional information is presented in *Appendix A*.

* In the interests of safety and as a service to the industry, Vekoma Rides Parts & Services B.V. issues technical information bulletins for the benefit of owners of amusement rides that are manufactured by Vekoma Rides Manufacturing B.V. (both companies are members of the Vekoma Rides B.V.). These bulletins may also contain technical information, on parts or modifications relating to amusement rides, manufactured by *Vekoma International B.V.* and / or *Vekoma Manufacturing B.V.* These are dissolved companies which have no legal relationship whatsoever with the Vekoma Rides B.V.

Vekoma Rides B.V. including its affiliated companies, agents and employees make no warranties and assume no responsibility for any misapplication or misinterpretation of the information provided, ride down time, consequential damages, loss, injuries, causes of action, claims, demands and expenses (including legal fees), of any kind or nature, arising directly or indirectly, in whole or in part, from or in relation to this technical information bulletin; nor for any amusement ride equipment built by any manufacturer(s) other than Vekoma Rides Manufacturing B.V.

All information relating to amusement rides, parts or modifications built or carried out by manufacturers other than Vekoma Rides Manufacturing B.V. and/or marked with an asterisk "*" are recommendations only and are not to be considered in any way to be advisory or mandatory, relied upon, nor imply any obligations or liabilities whatsoever.

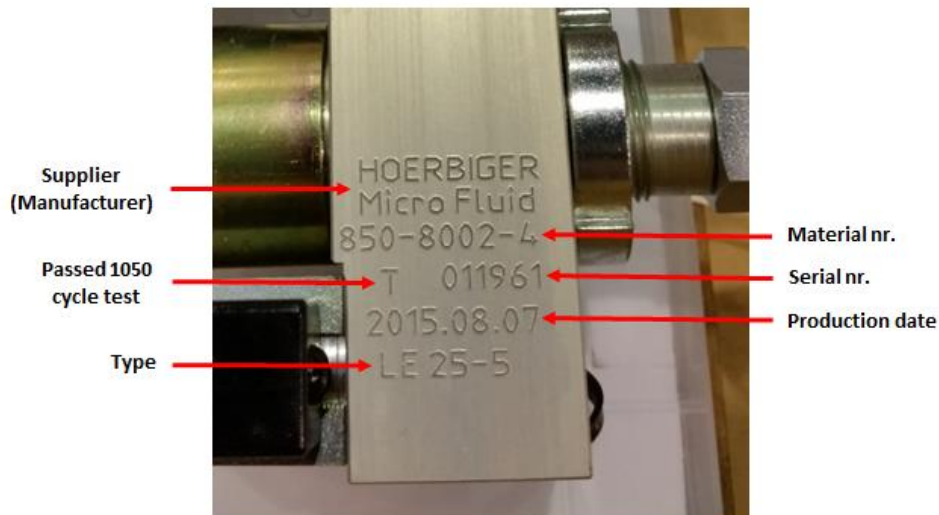

* In the interests of safety and as a service to the industry, Vekoma Rides Parts & Services B.V. issues technical information bulletins for the benefit of owners of amusement rides that are manufactured by Vekoma Rides Manufacturing B.V. (both companies are members of the Vekoma Rides B.V.). These bulletins may also contain technical information, on parts or modifications relating to amusement rides, manufactured by *Vekoma International B.V.* and / or *Vekoma Manufacturing B.V.* These are dissolved companies which have no legal relationship whatsoever with the Vekoma Rides B.V.

Vekoma Rides B.V. including its affiliated companies, agents and employees make no warranties and assume no responsibility for any misapplication or misinterpretation of the information provided, ride down time, consequential damages, loss, injuries, causes of action, claims, demands and expenses (including legal fees), of any kind or nature, arising directly or indirectly, in whole or in part, from or in relation to this technical information bulletin; nor for any amusement ride equipment built by any manufacturer(s) other than Vekoma Rides Manufacturing B.V.

All information relating to amusement rides, parts or modifications built or carried out by manufacturers other than Vekoma Rides Manufacturing B.V. and/or marked with an asterisk "*" are recommendations only and are not to be considered in any way to be advisory or mandatory, relied upon, nor imply any obligations or liabilities whatsoever.



Issuing Entity:	Bulletin No.: SB-033_02
Vekoma Rides Parts & Services B.V.	Release Date: 16-03-2016
Schaapweg 18	Effective Date: immediately
6063 BA VLODROP	Supersedes: SB-033_01
The Netherlands	Completion Date: 01-01-2017
CoC Number: 12049585	

3 General remark

Our advice is to clearly instruct your operators to follow the instruction in the Owner's Manual. Always check that the restraint is being closed as tightly as possible to the passenger's body. All restraints must be checked manually by pulling to see if they remain closed. Always check the restraint for locking before dispatch.

* In the interests of safety and as a service to the industry, Vekoma Rides Parts & Services B.V. issues technical information bulletins for the benefit of owners of amusement rides that are manufactured by Vekoma Rides Manufacturing B.V. (both companies are members of the Vekoma Rides B.V.). These bulletins may also contain technical information, on parts or modifications relating to amusement rides, manufactured by *Vekoma International B.V.* and / or *Vekoma Manufacturing B.V.* These are dissolved companies which have no legal relationship whatsoever with the Vekoma Rides B.V.

Vekoma Rides B.V. including its affiliated companies, agents and employees make no warranties and assume no responsibility for any misapplication or misinterpretation of the information provided, ride down time, consequential damages, loss, injuries, causes of action, claims, demands and expenses (including legal fees), of any kind or nature, arising directly or indirectly, in whole or in part, from or in relation to this technical information bulletin; nor for any amusement ride equipment built by any manufacturer(s) other than Vekoma Rides Manufacturing B.V.

All information relating to amusement rides, parts or modifications built or carried out by manufacturers other than Vekoma Rides Manufacturing B.V. and/or marked with an asterisk "*" are recommendations only and are not to be considered in any way to be advisory or mandatory, relied upon, nor imply any obligations or liabilities whatsoever.



Issuing Entity:	Bulletin No.: SB-033_02
Vekoma Rides Parts & Services B.V.	Release Date: 16-03-2016
Schaapweg 18	Effective Date: immediately
6063 BA VLODROP	Supersedes: SB-033_01
The Netherlands	Completion Date: 01-01-2017
CoC Number: 12049585	

Appendix A: official statement Hoerbiger

The official Hoerbiger statement regarding the lifetime of all HLU's (LE systems) can be found in the upcoming pages.

* In the interests of safety and as a service to the industry, Vekoma Rides Parts & Services B.V. issues technical information bulletins for the benefit of owners of amusement rides that are manufactured by Vekoma Rides Manufacturing B.V. (both companies are members of the Vekoma Rides B.V.). These bulletins may also contain technical information, on parts or modifications relating to amusement rides, manufactured by *Vekoma International B.V.* and / or *Vekoma Manufacturing B.V.* These are dissolved companies which have no legal relationship whatsoever with the Vekoma Rides B.V.

Vekoma Rides B.V. including its affiliated companies, agents and employees make no warranties and assume no responsibility for any misapplication or misinterpretation of the information provided, ride down time, consequential damages, loss, injuries, causes of action, claims, demands and expenses (including legal fees), of any kind or nature, arising directly or indirectly, in whole or in part, from or in relation to this technical information bulletin; nor for any amusement ride equipment built by any manufacturer(s) other than Vekoma Rides Manufacturing B.V.

All information relating to amusement rides, parts or modifications built or carried out by manufacturers other than Vekoma Rides Manufacturing B.V. and/or marked with an asterisk "*" are recommendations only and are not to be considered in any way to be advisory or mandatory, relied upon, nor imply any obligations or liabilities whatsoever.

Vekoma Rides Manufacturing B.V.
z.Hd. Herrn Van Heerten
Schnappweg 18

6063 BA Vlodrop
Niederlande

Barbing, 01/14/2016

Product information: Personal restraint hydraulic locks LE25 / LE32 for passenger restraint systems

Ladies and gentlemen,

This product information is intended as timely notification of an upcoming change in the maintenance requirements as they relate to our personal restraint hydraulic locks LE 25 / LE 32 for passenger restraint systems.

We have conducted broad analyses of the condition of used systems as part of returns and examinations of numerous LE locking systems. One result of these examinations is that the LE locking systems may exhibit wear patterns after 7 years – starting from the delivery date – and should therefore be replaced after this time period. We established the 7-year period independently of the intensity with which these systems are used since aging must also be considered.

From a quality and cost perspective, we have checked the option of an overhaul of the LE units after 7 years. We found that an overhaul/repair of used LE locking systems does not satisfy the cleanliness specifications due to the various washing processes of the overall system that are necessary, as well as those of the individual parts following disassembly. To ensure proper function, however, an overhaul must comply with the same high standard for cleanliness as new production.

Usage period of LE units

After carefully weighing these facts, we have come to the conclusion that an overhaul is not acceptable not only for quality reasons, but also from a cost perspective.



Starting from delivery, LE systems must be replaced with new LE systems after 7 years.

This applies notwithstanding previously communicated product documentation both to old systems already in use in the field and new systems currently in production.

This specification will take effect on January 1, 2017.

Contact person in case of questions

Mr. David Niemes
Tel +49 (0) 1622777287
E-mail david.niemes@hoerbiger.com

HOERBIGER Automatisierungstechnik Holding GmbH
Südliche Römerstraße 15
86972 Altenstadt

Determining the age of LE units

As of May 2015, the assembly date is embossed on the valve manifold of the LE unit (see image). Since HOERBIGER does not warehouse LE units, this date can also serve as the decisive date for replacement when conducting visual inspections.

The delivery date of older LE units can be determined based on the delivery note, or by HOERBIGER based on the material number and production order number, which can be found on the nameplate.

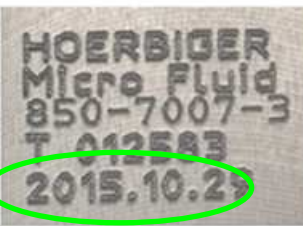
	Typenschild (vor 01. Mai .2015)	
	Das Typenschild befindet sich auf dem Außenrohr des Zylinders.	
	850-XXXX-X	Materialnummer
	4000YYYYYY	Fertigungsauftragsnummer
	Typ-Gravur (Ab 01. Mai 2015)	
	Die Typgravur befindet sich auf dem Ventilblock des Verriegelungssystems.	
	850-XXXX-X	Materialnummer
	T	1050 Test bestanden
	ZZZZZZ	Seriennummer
YYYY.MM.DD	Produktionsdatum (Jahr Monat Tag)	

Procedure

Affected systems can be identified and their replacement coordinated with HOERBIGER.

As we do not see any options for transition periods or substitute measures in this matter, we urge you to inspect your locking systems as soon as possible to determine when they are in need of replacement and to take the appropriate action.

Sincerely,

HOERBIGER Micro Fluid GmbH

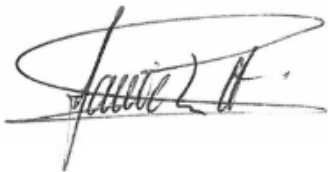

p.p. Daniel Schmitt
Manager Business Segment
Compact Motion Technology

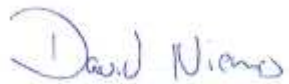

on behalf of David Niemes
Key Account Manager
Compact Motion Technology

Details of issue continued:

According to the ASTM F853/ F1193 latest revision:

Supplemental bulletins delivered by the manufacturer to the owner / operator that were not provided at the time of hand over of the amusement ride and contain new information or newly recommended inspections or testing, or both, will be released as a Safety Alert, Service Bulletin or an Notification, with the following criteria in order to carry the force and effect of this practice:

- “Safety Alert” For notifications that recommend immediate action.
- “Service Bulletin” For notifications that do not recommend immediate action but do recommend future action.
- “Notification” For notifications that do not necessarily recommend future action but are promulgation of information.



For additional information contact Vekoma Rides Parts & Services B.V.:

P.O. Box 8006, 6060 AA Posterholt
Schaapweg 18, 6063 BA Vlodrop,
The Netherlands

Tel: +31 (0) 475-409222 (office hours)
Cellphone: +31 (0) 6-10917506 (outside office hours)
Fax: +31 (0) 475-403415

Email: service@vekoma.com

Copyright © 2016

* In the interests of safety and as a service to the industry, Vekoma Rides Parts & Services B.V. issues technical information bulletins for the benefit of owners of amusement rides that are manufactured by Vekoma Rides Manufacturing B.V. (both companies are members of the Vekoma Rides B.V.). These bulletins may also contain technical information, on parts or modifications relating to amusement rides, manufactured by *Vekoma International B.V.* and / or *Vekoma Manufacturing B.V.* These are dissolved companies which have no legal relationship whatsoever with the Vekoma Rides B.V.

Vekoma Rides B.V. including its affiliated companies, agents and employees make no warranties and assume no responsibility for any misapplication or misinterpretation of the information provided, ride down time, consequential damages, loss, injuries, causes of action, claims, demands and expenses (including legal fees), of any kind or nature, arising directly or indirectly, in whole or in part, from or in relation to this technical information bulletin; nor for any amusement ride equipment built by any manufacturer(s) other than Vekoma Rides Manufacturing B.V.

All information relating to amusement rides, parts or modifications built or carried out by manufacturers other than Vekoma Rides Manufacturing B.V. and/or marked with an asterisk "*" are recommendations only and are not to be considered in any way to be advisory or mandatory, relied upon, nor imply any obligations or liabilities whatsoever.