



CHANCE RIDES MANUFACTURING, INC.
4200 Walker
Wichita, KS 67277-2328
U.S.A.
Phone: 1-316-945-6555 • FAX: 1-316-942-7416
Website: www.chancerides.com
E-mail: rides@chancerides.com

BulletinNo:	B403CRM174-A
Release Date:	March 9, 2016
Effective Date:	March 9, 2016
Supersedes:	B403CRM174-0
Completion Date:	See Text
Page:	1 of 4

SERVICE BULLETIN

Ride Name: 20-FOOT CARROUSEL (Model 409) Affected Serial Nos.: All Units
36-FOOT CARROUSEL (Model 404)
36-FOOT PTC CARROUSEL (Model 416)
36-FOOT DOUBLE DECKER CARROUSEL (Model 420)
28-FOOT CARROUSEL (Model 403)
28-FOOT PTC CARROUSEL (Model 415)
28-FOOT DOUBLE DECKER CARROUSEL (Model 426)
50-FOOT CARROUSEL (Model 405)

Model Nos.: 403, 404, 405, 409, 415, 416, 420 and 426

Abstract of Issue:
Crankshaft Inspection

Reason For Release:

Service bulletin B403CRM174-0 is superseded by this bulletin and is no longer in effect.

Chance Rides Manufacturing, Inc. has become aware of a failure of a CARROUSEL crankshaft. Failure of a crankshaft can result in the figure and/or the broken portion of the crankshaft falling. This can result in personal injury to passengers or bystanders.

Many factors can contribute to shortened service life of the crankshafts. These factors include, but are not limited to:

- Excessive backlash of the crankshaft drive box pinions
- Loose, worn or poorly maintained crankshaft U-joints
- Frequent and/or excessive ride operation with unbalanced loads
- Improper maintenance of the crankshaft bearings, horse pedestals and/or horse hanger bearings
- Heavy riders and/or heavy figures

This bulletin is being released to include annual non-destructive testing (NDT) requirements in addition to the monthly inspection of all crankshafts described in the appropriate *CARROUSEL Service Manual*. Details of all crankshaft inspection procedures are provided in this bulletin.

Action to be Taken:

Chance Rides Manufacturing, Inc. requires all owner/operators of the above noted CARROUSEL amusement rides to perform the NDT inspection described in this bulletin within 30 days of the issue date of this bulletin, and annually thereafter. The visual inspection described in this bulletin must be performed monthly.

If any indications are found, contact Chance Rides Manufacturing, Inc. immediately. Do not allow passengers to ride the figures connected to that crankshaft until the crankshaft is repaired or replaced.

All work must be performed by qualified personnel, capable of understanding the function of the parts and their proper installation. Use only those components authorized, specified or provided by Chance Rides Manufacturing, Inc. All applicable OSHA safety standards and safe industry practices must be observed.

Observe all safety information contained in the manufacturer's manuals. Make available this bulletin and all related technical information to personnel using the equipment.



CHANCE RIDES MANUFACTURING, INC.
4200 Walker
Wichita, KS 67277-2328
U.S.A.
Phone: 1-316-945-6888 • FAX: 1-316-942-7416
Website: www.chancerides.com
E-mail: rides@chancerides.com

BulletinNo: B403CRM174-A
Release Date: March 9, 2016
Effective Date: March 9, 2016
Supersedes: B403CRM174-0
Completion Date: See Text
Page: 2 of 4

Ride Manufacturer: CHANCE RIDES, INC.
CHANCE RIDES MANUFACTURING CO., INC.

Affected Production Dates: All

Ride Name: 20-FOOT CARROUSEL (Model 409)
36-FOOT CARROUSEL (Model 404)
36-FOOT PTC CARROUSEL (Model 416)
36-FOOT DOUBLE DECKER CARROUSEL (Model 420)
28-FOOT CARROUSEL (Model 403)
28-FOOT PTC CARROUSEL (Model 415)
28-FOOT DOUBLE DECKER CARROUSEL (Model 426)
50-FOOT CARROUSEL (Model 405)

Affected Serial Nos.: All Units

Model Nos.: 403, 404, 405, 409, 415, 416, 420 and 426

Detail of Issue

Crankshaft Inspection Procedure

Perform the inspections, described in detail on the following pages of this bulletin. These inspections are required on every crankshaft on the ride.

- NDT - Perform within 30 days of the issue date on this bulletin and annually thereafter.
- Visual Inspection - Perform monthly

Inspection Areas
See details on following pages

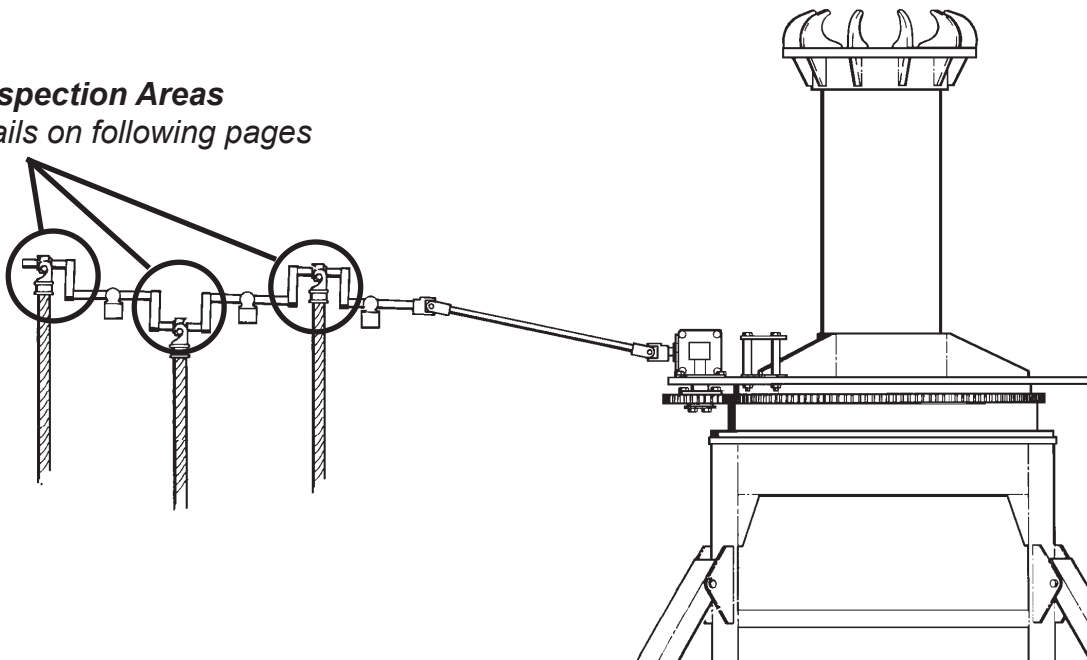

NOTE: 36-FOOT CARROUSEL shown. Other models are similar.



CHANCE RIDES MANUFACTURING, INC.
4200 Walker
Wichita, KS 67277-2328
U.S.A.
Phone: 1-316-945-6555 • FAX: 1-316-942-7416
Website: www.chancerides.com
E-mail: rides@chancerides.com

BulletinNo:	B403CRM174-A
Release Date:	March 9, 2016
Effective Date:	March 9, 2016
Supersedes:	B403CRM174-0
Completion Date:	See Text
Page:	3 of 4

Ride Manufacturer: CHANCE RIDES, INC. Affected Production Dates: All
CHANCE RIDES MANUFACTURING CO., INC.

Ride Name: 20-FOOT CARROUSEL (Model 409) Affected Serial Nos.: All Units
36-FOOT CARROUSEL (Model 404)
36-FOOT PTC CARROUSEL (Model 416)
36-FOOT DOUBLE DECKER CARROUSEL (Model 420)
28-FOOT CARROUSEL (Model 403)
28-FOOT PTC CARROUSEL (Model 415)
28-FOOT DOUBLE DECKER CARROUSEL (Model 426)
50-FOOT CARROUSEL (Model 405)

Model Nos.: 403, 404, 405, 409, 415, 416, 420 and 426

Detail of Issue (continued):

Crankshaft Inspection Procedure - Visual Inspection

Visually inspect the weld, the shaft and the throw in the area shown. Look for and record any indications in the weld and the heat affected area of the parent metal. This is a monthly inspection. .

IMPORTANT: *This visual inspection can be performed by a competent owner/operator.*

INSPECTION AREA
*Inspect the weld and the parent metal
in the area near every crankshaft throw*

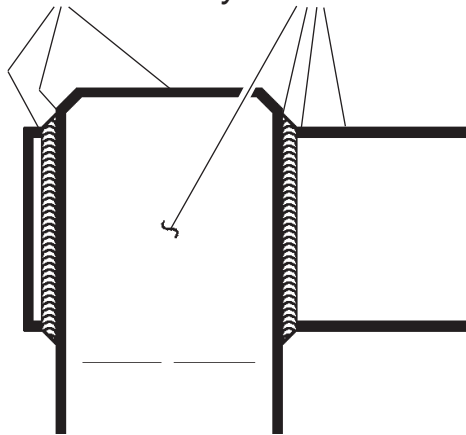

If any indications are found, contact the Customer Service Department at CHANCE RIDES MANUFACTURING, INC. for further instructions on replacement or repair of the crankshaft. Do not attempt to weld or otherwise repair the crankshaft except as specifically instructed by CHANCE RIDES MANUFACTURING, INC. Do not allow passengers to ride the figures connected to that crankshaft until the crankshaft is repaired or replaced.



CHANCE RIDES MANUFACTURING, INC.
4200 Walker
Wichita, KS 67277-2328
U.S.A.
Phone: 1-316-945-6888 • FAX: 1-316-942-7416
Website: www.chancerides.com
E-mail: rides@chancerides.com

BulletinNo: B403CRM174-A
Release Date: March 9, 2016
Effective Date: March 9, 2016
Supersedes: B403CRM174-0
Completion Date: See Text
Page: 4 of 4

Ride Manufacturer: CHANCE RIDES, INC. Affected Production Dates: All
CHANCE RIDES MANUFACTURING CO., INC.

Ride Name: 20-FOOT CARROUSEL (Model 409) Affected Serial Nos.: All Units
36-FOOT CARROUSEL (Model 404)
36-FOOT PTC CARROUSEL (Model 416)
36-FOOT DOUBLE DECKER CARROUSEL (Model 420)
28-FOOT CARROUSEL (Model 403)
28-FOOT PTC CARROUSEL (Model 415)
28-FOOT DOUBLE DECKER CARROUSEL (Model 426)
50-FOOT CARROUSEL (Model 405)

Model Nos.: 403, 404, 405, 409, 415, 416, 420 and 426

Detail of Issue (continued):

Crankshaft Inspection Procedure - NDT

Perform magnetic particle inspection on all the welded joints on the crankshafts per ASTM E709. Look for and record any indications in welds and the parent metal. This is an annual inspection.

IMPORTANT: This procedure must be performed by NDT personnel qualified in accordance with the American Society of Non-Destructive Testing (ASNT), SNT-TC-1A, certified as Level II or greater.

If any indications are found, contact the Customer Service Department at CHANCE RIDES MANUFACTURING, INC. for further instructions on replacement or repair of the crankshaft. Do not attempt to weld or otherwise repair the crankshaft except as specifically instructed by CHANCE RIDES MANUFACTURING, INC. Do not allow passengers to ride the figures connected to that crankshaft until the crankshaft is repaired or replaced.

Chance Rides Manufacturing, Inc. issues notifications for the benefit of owners of amusement rides manufactured by Chance Rides Manufacturing, Inc. As a service to the industry, and in the interest of employee and public safety, Chance Rides Manufacturing, Inc. also issues notifications for the benefit of owners of amusement ride equipment for which the manufacturer no longer exists, such as the Allan Herschell Company, Chance Manufacturing Co., Inc., Chance Rides, Inc., etc. In doing so, Chance Rides Manufacturing, Inc. does not assume liability for losses associated with amusement ride equipment built by manufacturers other than Chance Rides Manufacturing, Inc.