



**WISDOM
INDUSTRIES, Ltd.**

SERVICE BULLETIN

DATE: MARCH 7, 2005
RIDE: SIZZLER
SUBJECT: FOOTTUB BOLT ON PLATE ASSEMBLY

Recent Inspections of Sizzler foottub internal steel pivot plates have shown corrosion of the laminated steel. Inspection of the plates should be performed for all Sizzlers that are 8 years and older.

Plates that are corroded more than 20% of their thickness must be replaced.

An alternative to performing this inspection is to install a bolt on pivot plates or laminate galvanized plates into the foot tub.

A bolt on pivot plate kit is available that can be inspected without removing the fiberglass or foottub.

INSPECTION OF LAMINATED PLATES

1. Remove foottub from seat.
2. Grind from the inside the fiberglass overlaying the steel plates
3. Measure the thickness of the plate next to the boss. Plates that are cracked at the boss or measure less than .100" thick must be replaced. Prime, paint or galvanize plate before reinstalling.
4. Clamp plate into position.
5. Glass mat must extend 3 inches beyond the plate
6. Sand foot tub area that is to be glassed with 80 grit sandpaper.
7. Fiberglass over the plate with 3 layers of glass matt. Use quality polyester resin when glassing in the plate.
8. Reinstall foottub using NEW all steel locknut.
9. Measure clearance to gooseneck and sweep according to the attached instructions.
10. Check lap bar latching according to the attached procedure
11. Repeat on other side of foottub.

GALVANIZED PLATES

1. Remove non galvanized original plate
2. Clamp new plate into position and laminate into place using steps 4-11 in the inspection procedure.
 - NOTE: A small section of the plate can be left exposed to show that the plates are galvanized for subsequent inspections.

BOLT ON PLATES

1. Remove Lock nut from foottub pivot bolt
2. Remove pivot bolt so you can insert new foottub plates under edge of fiberglass.
3. Install new pivot bolt thru the plate and foottub.
4. Clamp new foottub plate against the back and side of fiberglass.
 - NOTE: If hole is oversized on foottub, line center of hole in plate with center of molded boss on outside of fiberglass foottub.
5. Drill 3/8" holes through fiberglass, using holes in new foottub plates as guide.
6. Insert 3/8" carriage bolt through from outside of fiberglass through new foottub plate and lock nut into place. 6 bolts and nuts per plate.
7. Install new pivot bolt.
8. Install new all metal locknut on foottub pivot bolt snug so foot tub will still fold up.

❖ **WARNING: At least 3 threads of the bolt must protrude from the 5/8" lock nut.**

9. Check lap bar latching according to the attached procedure
10. Check foot tub to sweep and gooseneck clearance before operation.
11. Repeat on other side of foottub.

Follow up inspection visually inspect the new plates for corrosion or cracks annually. The original steel can remain in the fiberglass.

Contact Wisdom Industries for replacement plates or bolt on plate kit and longer hinge bolts.

SIZZLER

LAP BAR & SEAT LOCK INSPECTION PROCEDURE

1. Raise lap bar and latch.
2. Check lap bar hinge bolts and pipe for wear or looseness.
3. Check lap bar arm for cracks.
4. Check that seat lock brass is tight.
5. Open lap bar.
6. Push seat lock pin. It must snap back out and not drag or catch.
7. Close lap bar. Seat lock pin must snap into the notch in the brass.
3/8 inch minimum engagement of pin in brass.

➤ **NOTE: ELECTRIC SEAT UNLOCKING IS NOT MANDATORY.**

8. Activate electric unlocking system.
NOTE: All seat locks should release.
9. Turn off electric unlocking system.
NOTE: The timer will shut off the solenoids after about 15 seconds.
10. Go around seat to inside (spindle side) and pull on the lap bar sideways and out to try to pop seat lock pin out of the brass.
11. If bar comes open, tie off that car until repairs are made. Replace any components needed if the bar will come open.
12. Repeat for each seat.

****WARNING****

Never install a bolt or knob to manually unlock the lapbar. Passengers have been known to open the bar while the ride is running and come out of the seat.

****NOTE****

Each seat lock pin is custom drilled for each car and lap bar. Make sure the same pin goes back to the same bar on the same car.

INSPECT CLEARANCE OF FOOTTUB TO SWEEP AND TRAILER GOOSENECK.

SEE ATTACHED BULLETIN.

Please notify Wisdom Industries following this inspection and notify us to the status of the bolts on your ride. If you have any questions, please contact Wisdom Industries at 800-634-6097.

MAY 28, 1997 - 14:07:05 : < F:\SIZZ-DWG\SEAT >

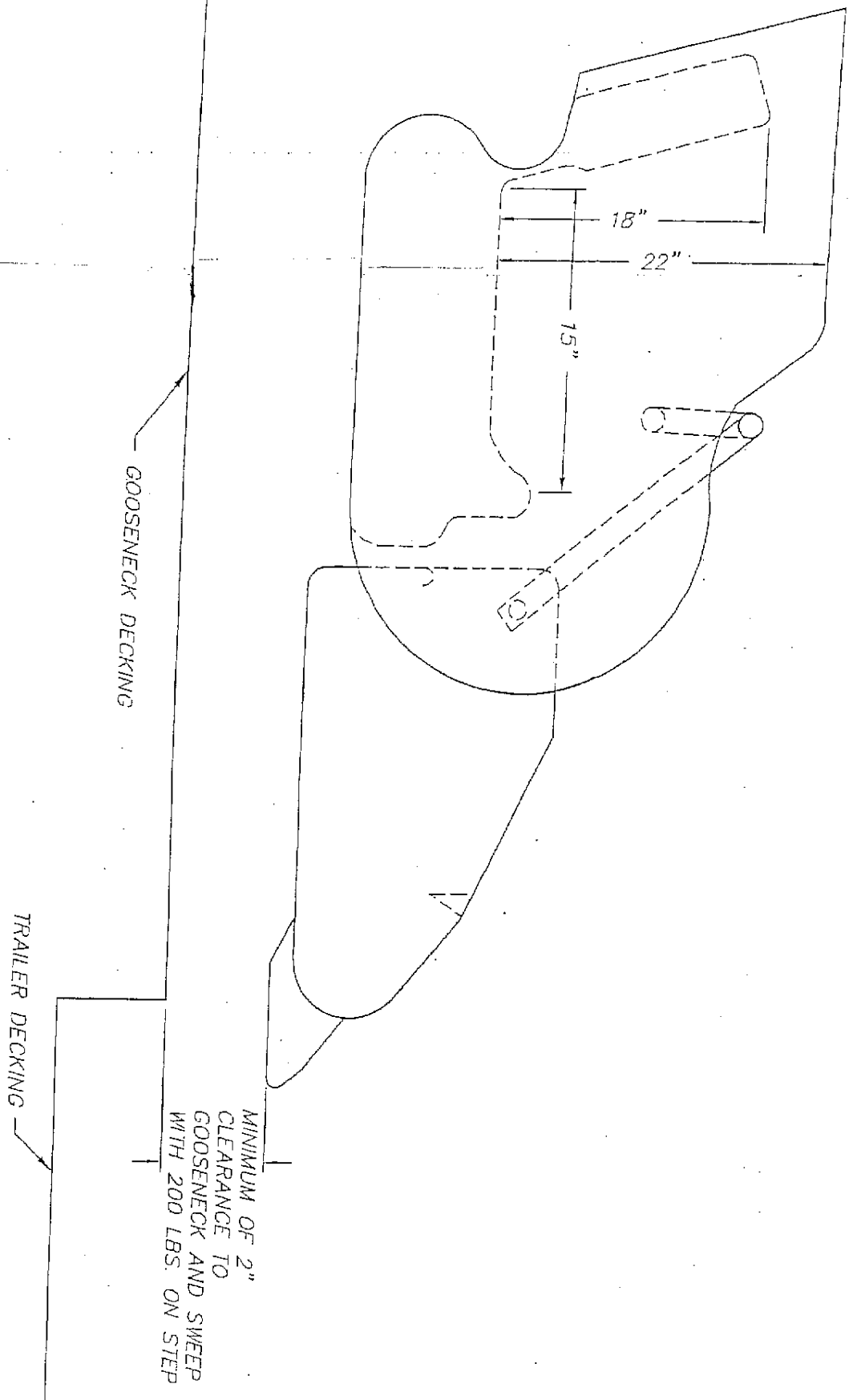

GOOSENECK DECKING

TRAILER DECKING

MINIMUM OF 2"
CLEARANCE TO
GOOSENECK AND SWEEP
WITH 200 LBS. ON STEP

REMOVE LOCK NUT FROM FOOT TUB PIVOT BOLT.

SLIDE PIVOT BOLT OUT SO YOU CAN
INSERT NEW FOOT TUB PLATES UP UNDER EDGE
OF FIBERGLASS .

TAP PIVOT BOLT BACK THRU SO
NEW FOOT TUB PLATE IS ON BOLT.

CLAMP NEW FOOT TUB PLATE BACK AGAINST
THE BACK AND SIDE OF FIBERGLASS .

NOTE: IF HOLE IS OVERSIZED ON FOOT TUB
ALIGN CENTER OF HOLE IN PLATE WITH CENTER
OF MOLDED BOSS ON OUTSIDE OF FIBERGLASS FOOT TUB

DRILL 3/8" HOLES THRU FIBERGLASS, USING
HOLES IN NEW FOOT TUB PLATES AS GUIDE.

INSERT 3/8" CARRAGE BOLT THRU FROM OUTSIDE OF
FIBERGLASS THRU NEW FOOT TUB PLATE AND LOCK NUT
INTO PLACE. 6 BOLT& NUTS PER PLATE.

REPLACE LOCK NUT ON FOOT TUB PIVOT BOLT.
WITH NEW ALL METAL LOCKNUT
SNUG SO FOOT TUB WILL STILL FOLD UP.

WARNING: AT LEAST 3 THREADS MUST PROTUDE
FROM THE LOCKNUT.

REPEAT ON OTHER SIDE OF FOOT TUB.

CHECK: LAPBAR LATCHING ACCORDING
TO ATTACHED PROCEDURE.

CHECK: FOOT TUB TO SWEEP AND GOOSENECK
CLEARANCE BEFORE OPERATION.

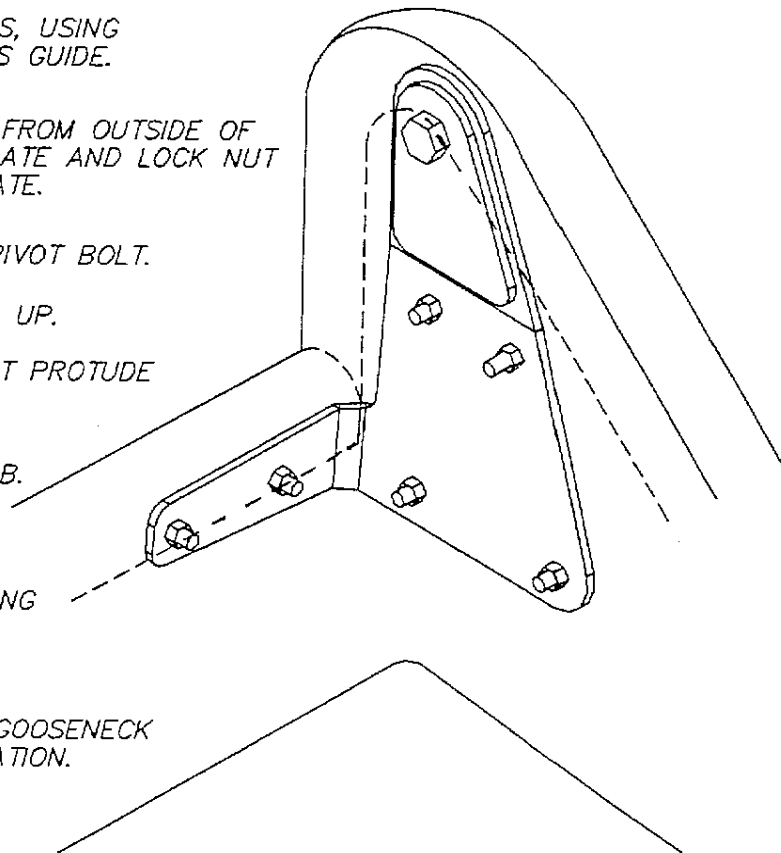

WISDOM
INDUSTRIES

Merino, CO 80741

APPROVED BY

FOOT TUB BOLT ON PLATE INSTALLATION

SCALE: NTS

DATE: 3-07-05

SIZZLER

DESIGNED BY

M.HICKAM

DRAWING NUMBER

01E035E