



Number: B376R1017-0

Date: September 9, 1987

Supersedes:

SERVICE BULLETIN

Effective Serial Numbers: All Units

Ride: YO YO

Subject: Trailer Set-Up, Loading
And Operation

As a safety precaution, CHANCE RIDES, INC. requires that owners of all YO YO amusement rides instruct their employees on the proper procedures and instructions contained in this bulletin.

TRAILER SET-UP

1. Inspect the blocking under each of the four (4) leveling jacks and eight (8) screw jacks under the front and rear trailer sections. Good, solid blocking, preferably wooden 3 x 12's, must be placed under each jack point. As blocks are stacked, criss-cross each layer, ending the stack with a single block as shown in the following illustrations.

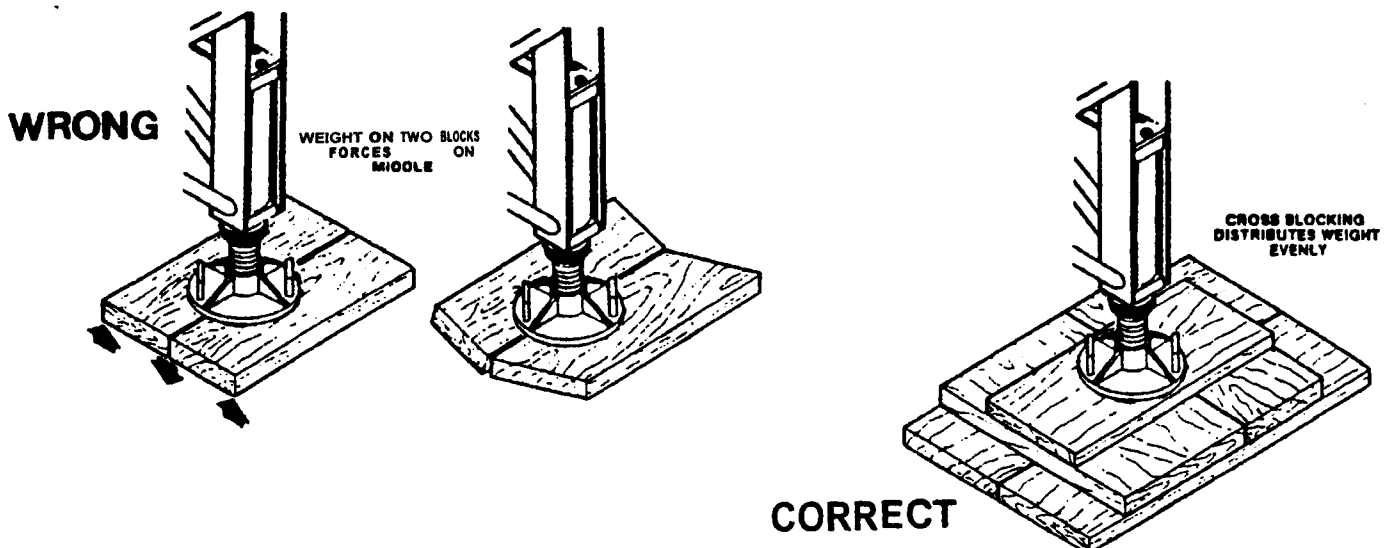

2. Make sure the lock rings on the leveling jacks are tight against the bottom of the jack. All needle valves and the hand pump valve must be OPEN to relieve hydraulic pressure in the leveling jacks. This is important because hydraulic oil in the jacks can expand when exposed to heat, such as direct sunlight, causing the jack to extend.

3. The tie bar and five turnbuckles must be secured with the CORRECT PINS AND HAIRPINS as specified in the illustration below. Do not substitute bolts or any other hardware. The turnbuckles must be tightened so that the mating V-blocks on sections of the trailer are snug.

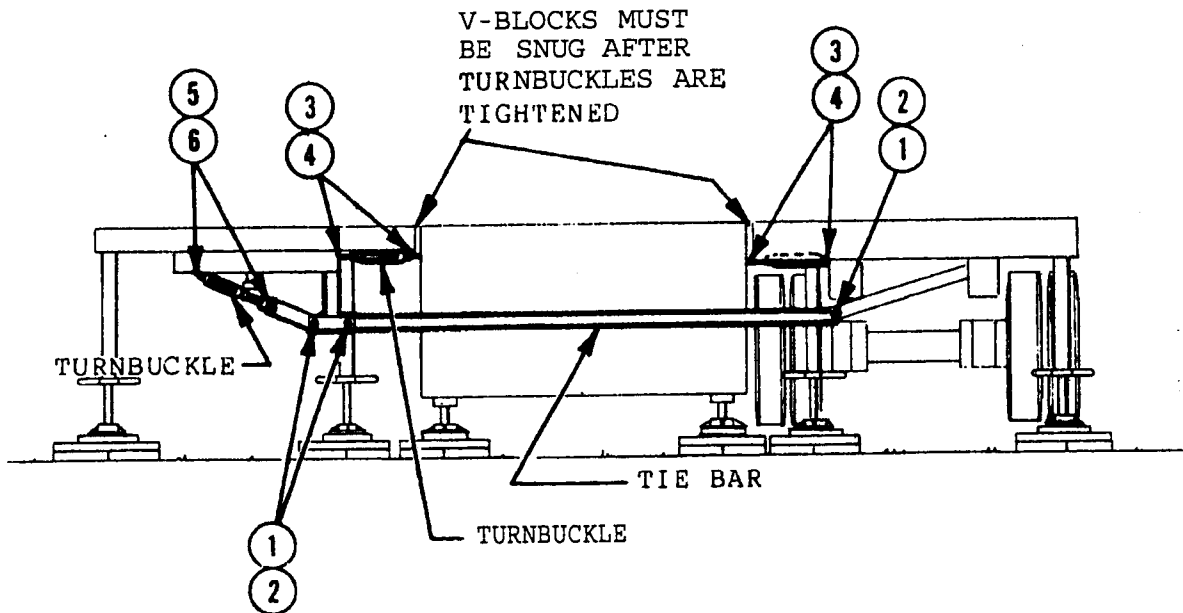

<u>REF. NUMBER</u>	<u>PART NUMBER</u>	<u>DESCRIPTION</u>	<u>QUANTITY REQUIRED</u>
1	390-52295	TAPER PIN (CSN10A05-02)	3
2	694-51902	HAIRPIN (5/32 Diameter)	3
3	390-52296	TAPER PIN (CSN10A05-03)	8
4	694-51902	HAIRPIN (5/32 Diameter)	8
5	390-52491	TAPER PIN (CSN10A06-03)	2
6	694-51904	HAIRPIN (3/16 Diameter)	2

LOADING AND OPERATION

If the ride is being operated at less than its full passenger capacity, direct the passengers around the ride to balance the load. NEVER OPERATE THE RIDE WITH AN IMBALANCE OF MORE THAN SIX (6) ADULTS ON ANY ONE SIDE OF THE RIDE.