



CHANCE
MANUFACTURING CO., INC.

Number: 06-158
Date: 4-25-78

Supersedes:
Number:
Date:

America's Largest Manufacturer of Amusement Rides

Service Information

Effective Serial Numbers: 69-2101 AND ON

Ride: TOBOGGAN Subject: SEAT INSPECTION

The following inspection is to be performed on all Toboggan rides. If any part or circuit fails to function as described, stop operation of the ride until the conditions have been corrected.

The inspection must be performed by qualified mechanics capable of understanding the function of the parts and their proper installation.

If you have any questions concerning this inspection, please notify Chance Manufacturing for assistance.

Inspect adjusting cap screw in end of each catch dog. Cap screw must not be broken, bent or worn. The catch dog must operate so that the cap screw is centered on the stop.

Catch dog adjusting cap screw must be adjusted so that catch dog leg just contacts bottom of safety track.

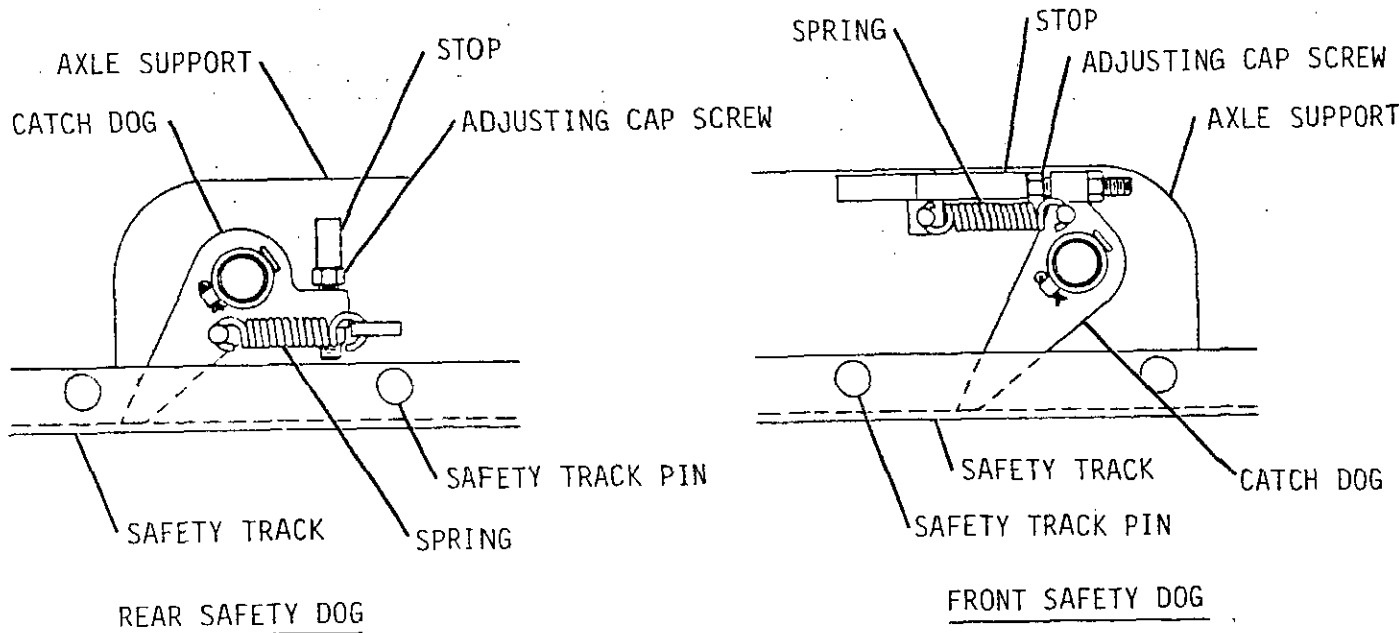

Factory and General Office, 4219 Irving, P.O. Box 12328 Wichita, Kansas 67277
Sales Office: 1103 Ross Ave., Dallas, Texas 75202

Area Code (316) 942-7411
Area Code (214) 742-3802

Inspect catch dog stops for bending, cracking and wear.

Inspect safety track to see that all pins are in place and are not bent or worn.

Each catch dog is held in the rest position by two springs. Both springs must be used. Springs must not be stretched out of shape and must hold the catch dog so that the head of the adjusting cap screw is held firmly against the stop.

When securing cars for transporting, hold car so that latch dog is firmly against safety track pin. Attach at least one track clamp behind each car. This should hold cars firmly so that there can be no fore and aft movement of the car. Attach "J" bolt with plate end to car and hook end of bolt on track. Car must be held firmly so that there is no movement during transporting.



TRACK CLAMP

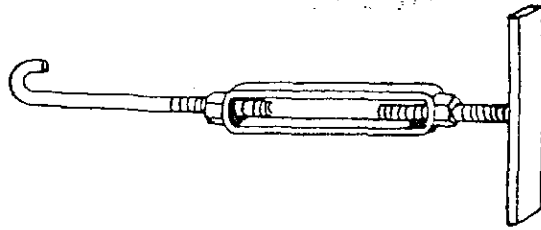

J-BOLT

The chain dog latch and the trip arm are held in the catch position by two springs. Both springs must be used. The springs must not be stretched out of shape and must hold the chain dog latch and the trip arm firmly against the stop. Chain dog latch must hold chain dog securely in the latched position.

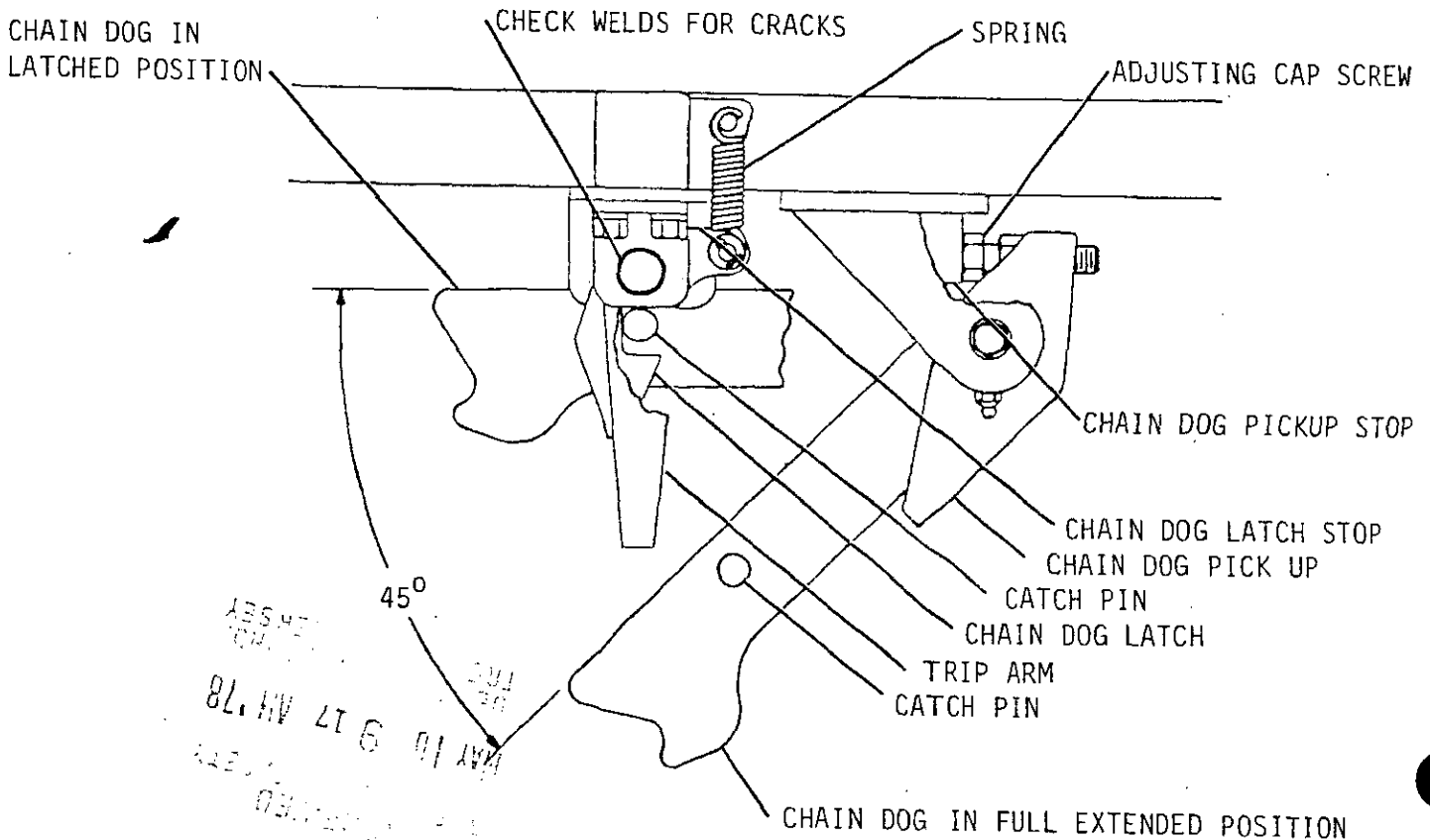

CHAIN DOG ASSEMBLY

Chain dog latch and trip arm mounting shaft must pivot easily and mounting bolts should be tight. Check all welds for cracks.

Chain dog and chain dog pick up must be held securely on mounting shaft by a key and two set screws each. Mounting shaft must pivot freely with no binding. Chain dog must swing 45° from the latched position to the fully extended position when the chain dog adjusting screw is against the stop.

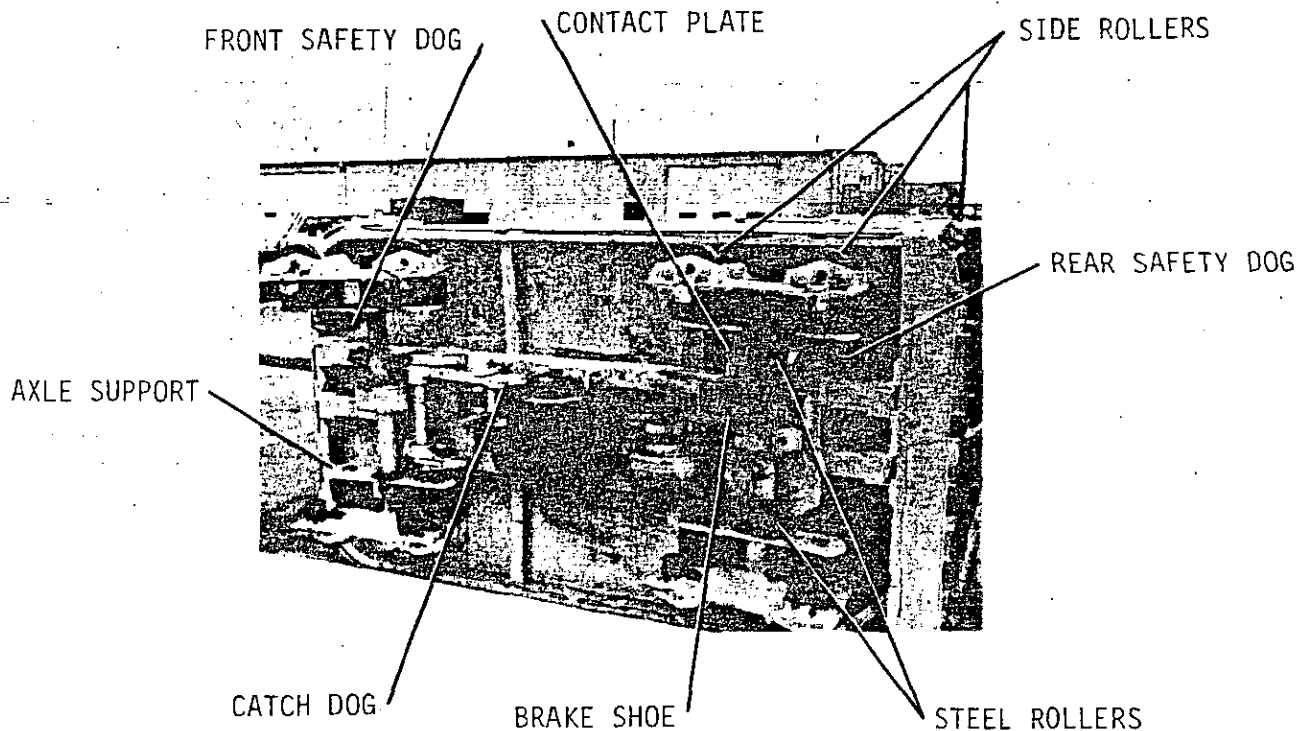

Each axle has two side rollers at each end. If these rollers become worn or loose, the axle may move to one side and not allow the catch dog to be centered in the track. Inspect side rollers for wear on the outside surface and on the inside where the bolt holds it in position. Also inspect the bolt for wear. Minimum outside diameter of roller is 3-5/8". Rollers must turn freely with no binding.

Inspect top rollers at each axle support for wear. Minimum outside diameter is 3-3/4". Rollers must turn freely with no binding.

Inspect the two steel rollers on the rear axle of each car. Hold either roller against the contact plate on the car frame and check the clearance between the other roller and contact plate. Plates must not be worn and clearance must be no more than 1/4". Rollers must turn freely with no binding.

Inspect bottom rollers at each axle support to see that they are mounted securely and turn freely with no binding.

Inspect brake shoe located on rear axle of the cars. Brake shoes must not be less than 3/8" thick at the thinnest point.

Inspect all track brake components for worn, bent or broken pins, worn mounting holes and bent or worn brake bars.

Inspect the rubber stops that restrict the upward movement of the brake bars. Rubber stops should not be cracked, torn or deteriorated.

Inspect emergency brakes on the tower spiral track by sending an empty car down the track while the emergency brakes are applied. Car must stop when it contacts the brakes.

Check the function of the emergency brake on the return track by disconnecting the air line to the air chamber. The loss of air pressure will allow the two coil springs to apply the brake. When the air line is reconnected the air pressure will cause the air chamber to compress the springs and release the brakes. Check both springs to see that they are not broken.

A limit switch located at the top of the entrance to the tower will shut off the power to the chain drive when it is contacted by a hatch which has been left open on a car. Activate the switch by flexing the "whisker" which hangs down from the switch. This will turn off power to the drive chain until the "CHAIN RESET" switch on the operators hand control box is activated.

To check the circuit which allows only one car in the tower at a time, release the brake closest to the tower and allow a car to enter the tower. Do not advance the other cars. While the car is still in the tower again try to release the brake closest to the tower. Brake should not release until the car has moved out of the tower. The circuit also has a bell which should ring as the car exits the tower.

APPROVED
82. 11 27 6 11 AM
AIE-10
GARRISON



Number: B06-0180-00

Date: 1-22-79

CHANCE
MANUFACTURING CO., INC.

Supersedes:

America's Largest Manufacturer of Amusement Rides

Service Bulletin

Effective Serial Numbers: ALL RIDES

Ride: TOBOGGAN

Subject: MAINTENANCE INSPECTION

If you no longer own this ride please notify Chance Manufacturing Co. of new owners name and address.

This bulletin is being issued to point out in detail several operating and maintenance practices on the Toboggan that are necessary to maintain the safety of the ride. These items should be checked daily along with the remainder of the FIELD INSPECTION POINTS listed at the end of this bulletin.

Inspection of the ride must be performed by competent, qualified mechanics capable of understanding the function of the parts and their proper installation.

All welding must be performed by a welder that is certified under the American Welding Society Structural Welding Code D1.1-75 or the equivalent.

All references to the Toboggan refer exclusively to the Toboggan Operations Manual and Parts Catalog dated January 6, 1972 on the front cover. All other manuals have been superceded and are no longer in effect. Copies of the current manual are available from the factory at no charge.

Page numbers are given with each heading and item call outs are given in the text for easy reference to the parts in the Turbo Manual.

SEAT HATCH LATCHES (SEE TOBOGGAN MANUAL PAGE 90)

Inspect seat door latches before each day's operation and when ride is set up. The spring operated latch is used as the primary latch and a hair pin is used as a secondary safety pin on the hatch latching mechanisms. Both the spring operated latch and hair pin latch must be in good working order before the ride can be operated. In no event should a seat be used if either one of the latches is not in good working order.

Factory and General Office, 4219 Irving, P.O. Box 12328 Wichita, Kansas 67277

Area Code (316) 942-7411

Sales Office:

1103 Ross Ave., Dallas, Texas 75202

Area Code (214) 742-3802

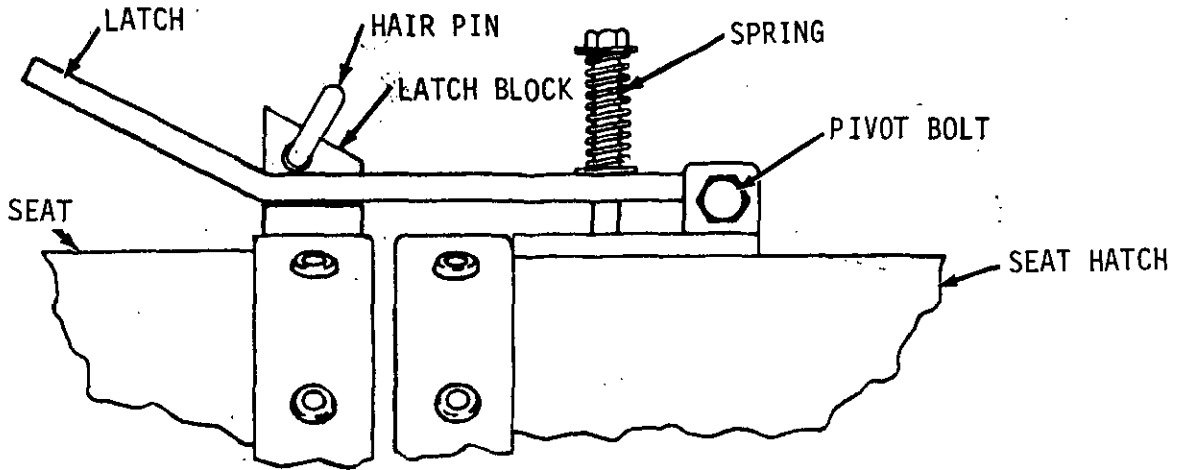

FIGURE A

The pivot bolts for the spring operated latch must be tight and the latch must pivot freely with no binding. The latch must close over the latch block without binding. The spring must not be distorted and must hold the spring latch tight against the shoulders on the latch block when the hatch is closed.

When the spring latch is in the latches position the hair pin hole in the latch block must be fully exposed. The amount of material between the top of the hair pin hole and the top of the latch block must fall within the tolerances shown in FIGURE B.

If the tops of the latch ears or the latch arm become worn beyond the allowable tolerance they may be built up by welding and then ground down to the allowable tolerance.

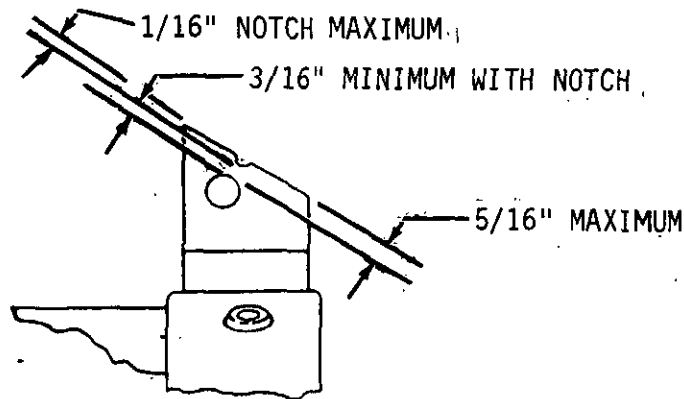

FIGURE B

Hair pins must be inserted and removed from the latch by hand only. If hair pin cannot be inserted by hand correct the misalignment condition.

A new hairpin inserted in a latch having maximum 5/16" edge of hole to edge of ear thickness (See FIGURE B) will require the maximum force to insert and remove.

A hairpin inserted in a latch having a worn or notched condition that reduces the edge of hole to edge of ear thickness to a minimum allowable of 3/16" (See FIGURE E), will require less force to insert.

Latch hairpins are expendable items and will become sprung after repeated use. Clearance at the inner lobe of the hairpin, FIGURE C, must always be at least 1/16" less than the edge of hole to edge of ear thickness or be replaced. This ensures a reasonable amount of force (approximately 8 pounds or more) will be required to insert or remove the hairpin. A hairpin that is easily inserted and removed must not be used under any condition.

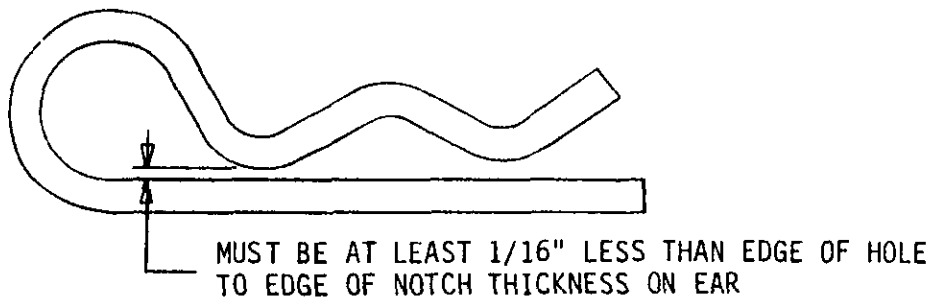

FIGURE C LATCH HAIR PIN

Do not use a hammer to insert or remove the hair pins. Using a hammer may cause the hair pin to turn to one side and be forced over the ear in a position where the material thickness is greater than the hair pin is designed for. This can cause the hair pin to be sprung beyond its usable dimensions. Do not insert hair pin past the second lobe.

SEAT HATCH LATCHES WHICH CANNOT BE MAINTAINED OR REPAIRED MUST BE REPLACED.

SEAT HATCH (SEE TOBOGGAN MANUAL PAGE 90)

Check to see that hinge bolts are tight and in good working order. Hatch must open and close without binding. Check all hinges for wear. Check the hatch linkage (D THRU M) on the left side of the hatch to see that it does not bind when the hatch is opened or closed. Attaching bolts for the hatch linkage and the lap bar must be tight. Plexiglass windows must be in place and unbroken.

Inspect car and hatch to see that there are no restrictions that will keep the hatch from closing properly. Do not fasten hair pin to car or hatch. Chain may fall in opening and restrict hatch from closing properly.

SEAT CONDITION (SEE TOBOGGAN MANUAL PAGE 90)

Check the general condition of the car. See that the screening is not torn or loose and that there are no sharp edges. The padding on the seat and on the lap bar must be fastened securely and not be torn or split.

HYDRAULIC SYSTEM (SEE TOBOGGAN MANUAL PAGE 54)

The most important thing with any hydraulic system is to keep it clean. Change filters twice yearly. After any work which opens up the system, such as an oil change or replacing or repairing the control valve, the filter should also be changed. When the oil is changed manually, the strainer inside the tank should be cleaned, also. Remove the strainer from the tank to clean. Clogged strainers will starve the pumps and ruin them beyond repair. Some of the first signs of damaged pumps are excessive pump noise or the ride running slowly, especially when the oil is hot.

It is very important to keep the oil at the proper level in the tank. The ride will operate on much less than a full tank, but the tank must be full when the ride is racked and the leveling jacks are raised, or the hydraulic system can overheat. Overheating can damage almost every component in the system. The recommended operating temperature is 140° to 180°.

LEVELING JACKS (SEE TOBOGGAN MANUAL PAGES 11 and 70)

Leveling jacks (page 11) have a stroke of 9" and are hydraulically extended and spring retracted. As the leveling jack reaches the end of its stroke the hand pump (page 11) will get harder to operate. The leveling jack should not be extended past this point as damage may result to the piston (Item D, page 70) and the ram spring (Item H, page 70). To help prevent overstroking place as much blocking as possible under the jack pads before extending the leveling jacks. Inspect leveling jacks for leaks each time the ride is set up or torn down. Leaks are usually the result of damaged seals (Item E, page 70) or scratched cylinder walls (Item B, page 70).

Hydraulic pressure may increase due to expansion when leveling jacks are exposed to heat such as direct sun light. The increased pressure may cause the leveling jack to raise the ride off of the locking rings (page 11) and make the ride unstable. After ride is leveled and locking rings have been tightened, open needle valves (page 11) and hand pump valve (page 11) to relieve pressure on the leveling jacks. When racking the ride, close the valves and operate the hand pump and the needle valves to extend each of the leveling jacks so that the weight is lifted off of the locking rings. Locking rings can then be backed off so that leveling jacks can be retracted.

ALIGNMENT OF TRAILERS (SEE TOBOGGAN MANUAL PAGE 12)

Check the alignment of the main trailer to the auxilliary trailer and see that the two attaching turnbuckles are tight. Check for movement of auxilliary trailer when car moves around curved section of track at end of auxilliary track. Screw jacks under auxillary trailer must be in place and tight.

TRACK (SEE TOBOGGAN MANUAL PAGES 57-68 and 76-85)

Check all sections of track, track braces and track supports for worn mounting holes, taper pins and hairpins. All turnbuckles must be tight.

LIFT CHAIN AND SPROCKETS (SEE TOBOGGAN MANUAL PAGES 19, 78 and 80)

Check car lift chain and sprockets at bottom and top of barrel for wear and alignment. Check sprocket shafts for wear. Chain must not have more than 3 inches of slack vertically between sprockets at bottom of tube. Check lift chain for broken rollers.

TOWER (SEE TOBOGGAN MANUAL PAGES 16 and 18)

Check tower lockup pins, bolts and holes for wear. Check for movement of barrel at bottom when car comes out the top of barrel.

GOOSENECK (SEE TOBOGGAN MANUAL PAGES 78 and 82)

Check gooseneck pivot pin (Item H, page 78) and hole for wear. Gooseneck turnbuckles must be tight.

RIDE SPEED

Check the speed of the ride by recording the time it takes for each car, when fully loaded, to complete a full cycle. Time must not be less than 45 seconds.

TORQUING OF BOLTS - (SEE SERVICE BULLETIN 90-148B)

All structural bolts must be periodically be checked for tightness. Refer to Service Bulletin 90-148B for proper torque values. Notify Chance Mfg. Co. of any bolts that are frequently found loose.

ADDITIONAL INSPECTION POINTS

Perform additional inspection points outlined in Service Bulletin B06-0158A00 and the Toboggan Manual.

The attached Certification of Compliance must be completed and returned to Chance Manufacturing Co. within seven (7) days of receipt of kit.

If you have any questions concerning this bulletin, please contact Chance Manufacturing Co. for assistance.

DAILY INSPECTION

1. Check spring latches to see that they open and close without binding.
2. Check spring latch springs to see that they are not distorted or broken.
3. Check to see that springs will hold spring latches in the latched position.
4. Check latch block to see that hair pin hole is fully exposed when the spring latch is depressed.
5. Check material thickness on latch blocks.
6. Check hair pins to see that they are not sprung.
7. Check operation of the hatches. Hinge bolts must be tight and hatches must open and close without binding.
8. Check attaching bolts for hatch linkages and lap bars.
9. Check to see that plexiglass windows are in place and unbroken.
10. Check for restrictions that would prevent hatches from closing properly.
11. Check seats for loose screening and sharp corners.
12. Check seats and lap bars for missing padding.
13. Check hydraulic oil for contamination and overheating.
14. Check hydraulic oil level.
15. Check leveling jacks for leaks.
16. Check leveling jack lock rings.
17. Check setting of hand pump valve and needle valves.
18. Check blocking under leveling jacks.
19. Check alignment of trailers to each other.
20. Check turnbuckles that tie trailers together.
21. Check for movement of auxilliary trailer during operation of ride.
22. Check the position and tightness of jackstands under auxilliary trailer.
23. Check lift chain and sprocket for wear and alignment.
24. Check adjustment of lift chain.
25. Check lift chain for broken rollers.
26. Check tower lockup pins, bolts and holes for wear.
27. Check for movement of barrel at bottom during operation of ride.
28. Check gooseneck pivot pin and hole for wear.
29. Check gooseneck turnbuckles for tightness.
30. Check speed of ride.
31. Check all structural bolts for proper torque.
32. Check ride for proper lubrication as outlined in the Toboggan Manual.
33. Check all maintenance points outlined in the Toboggan Manual.

NOTE: THE FOLLOWING INSPECTION POINTS ARE EXPLAINED IN DETAIL ON SERVICE BULLETIN B06-0158A00.

34. Check condition and adjustment of catch dog and spring.
35. Check the condition of the safety track.
36. Check for proper use of track clamp and J-bolt.
37. Check condition and adjustment of chain dog and chain dog pickup.
38. Check condition of chain dog latch, trip arm and spring.
39. Check all rollers and bearings on bottoms of cars.
40. Check condition of brake shoes on cars.
41. Check condition of track brake components.
42. Check the condition and operation of the emergency brakes.
43. Check the operation of the "hatch open" limit switch.
44. Check the operation of the circuit which allows only one car in the tower at a time.

THE FOLLOWING FIELD INSPECTION POINTS MUST ALSO BE CHECKED DAILY

1. Check for proper grounding per local code.
2. Check for proper installation of fences, steps and handrails.
3. Check ride for excessive vibration.
4. Check structure for cracks, bad welds, etc.
5. Check electrical circuit for shorts, bad wires, etc.
6. Check for hydraulic leaks.
7. Check rides' overall appearance for cleanliness and general external upkeep.



Number: B06-0158A00

Date: 1-22-79

CHANCE
MANUFACTURING CO., INC.

Supersedes: 06-158

America's Largest Manufacturer of Amusement Rides

Service Bulletin

Effective Serial Numbers: 69-2101 AND ON

Ride: TOBOGGAN

Subject: SEAT INSPECTION

If you no longer own this ride please notify Chance Manufacturing Co. of new owners name and address.

This bulletin supersedes bulletin 06-158 which may have contained misleading or erroneous information. Destroy all copies of 06-158 immediately.

The following inspection is to be performed on all Toboggan rides. If any part or circuit fails to function as described, stop operation of the ride until the conditions have been corrected.

The inspection must be performed by qualified mechanics capable of understanding the function of the parts and their proper installation.

If you have any questions concerning this inspection, please notify Chance Manufacturing for assistance.

Inspect adjusting cap screw in end of each catch dog. Cap screw must not be broken, bent or worn. The catch dog must operate so that the cap screw is centered on the stop.

Catch dog adjusting cap screw must be adjusted so that catch dog leg is 1/8" from bottom of safety track.

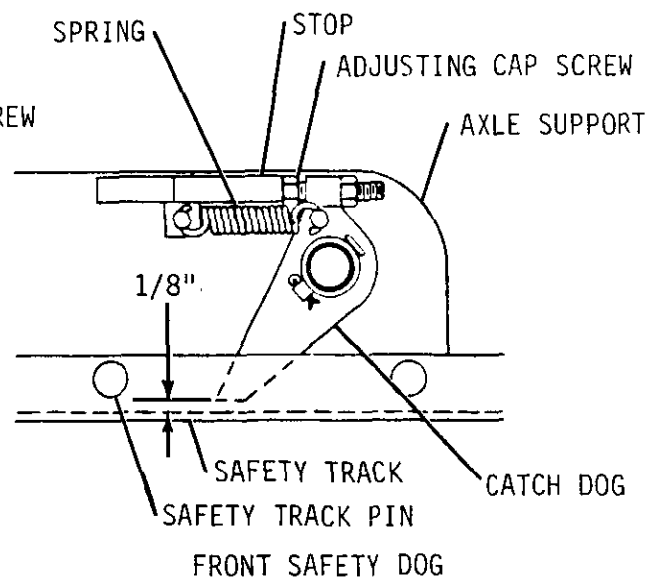
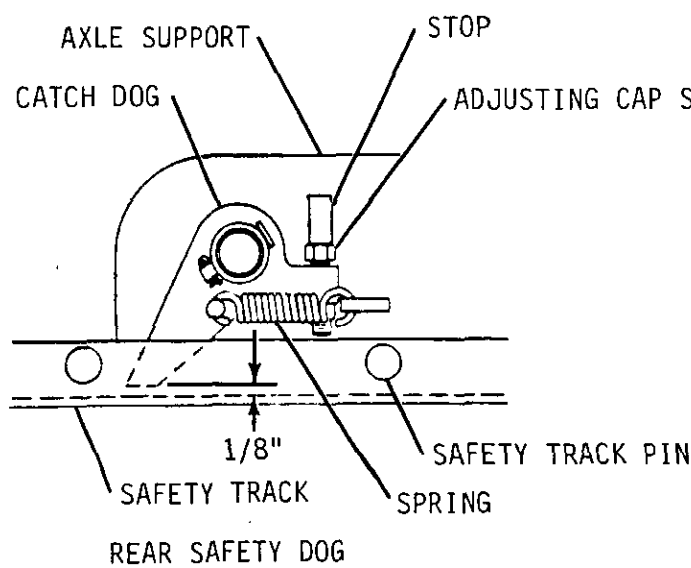

Factory and General Office, 4219 Irving, P.O. Box 12328 Wichita, Kansas 67277

Area Code (316) 942-7411

Sales Office:

1103 Ross Ave., Dallas, Texas 75202

Area Code (214) 742-3802

Inspect catch dog stops for bending, cracking and wear.

Inspect safety track to see that all pins are in place and are not bent or worn.

Each catch dog is held in the rest position by two springs. Both springs must be used. Springs must not be stretched out of shape and must hold the catch dog so that the head of the adjusting cap screw is held firmly against the stop.

When securing cars for transporting, hold car so that latch dog is firmly against safety track pin. Attach at least one track clamp in front of each car. This should hold cars firmly so that there can be no fore and aft movement of the car. Attach "J" bolt with plate end to car and hook end of bolt on track. Car must be held firmly so that there is no movement during transporting.



TRACK CLAMP

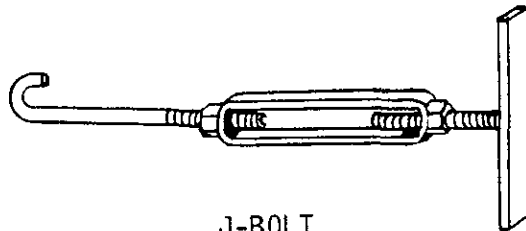

J-BOLT

The chain dog latch and the trip arm are held in the catch position by two springs. Both springs must be used. The springs must not be stretched out of shape and must hold the chain dog latch and the trip arm firmly against the stop. Chain dog latch must hold chain dog securely in the latched position. Check chain dog latch and trip arm for wear.

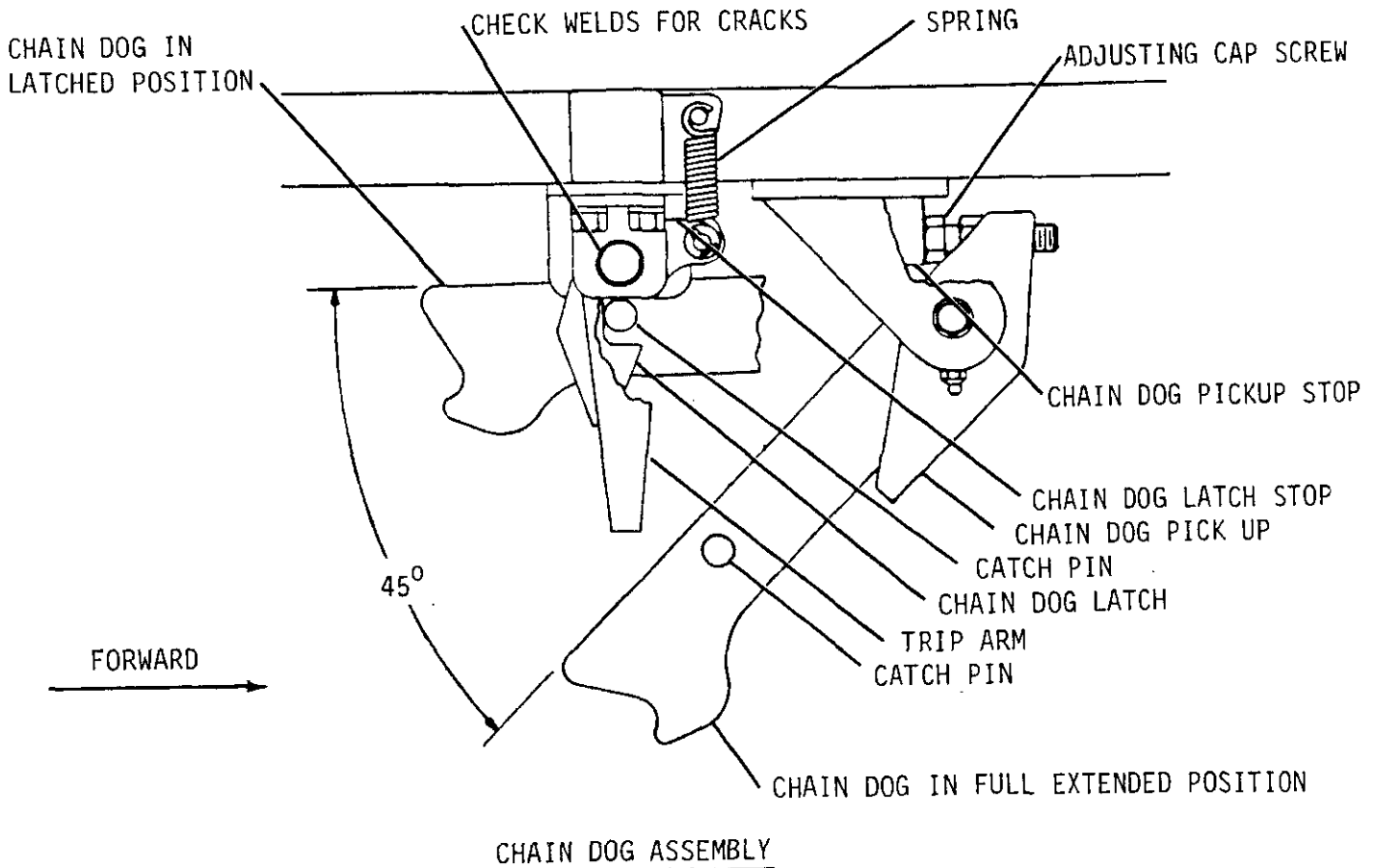

Chain dog latch and trip arm mounting shaft must pivot easily and mounting bolts should be tight. Check all welds for cracks.

Chain dog and chain dog pick up must be held securely on mounting shaft by a key and two set screws each. Mounting shaft must pivot freely with no binding. Chain dog must swing 45° from the latched position to the fully extended position when the chain dog adjusting screw is against the stop.

Check chain dog and chain dog pick up for wear. Chain dog pick up must contact striker plate on track when car leaves top of barrel and trip chain dog into latched position. Do not operate ride if chain dog will not latch.

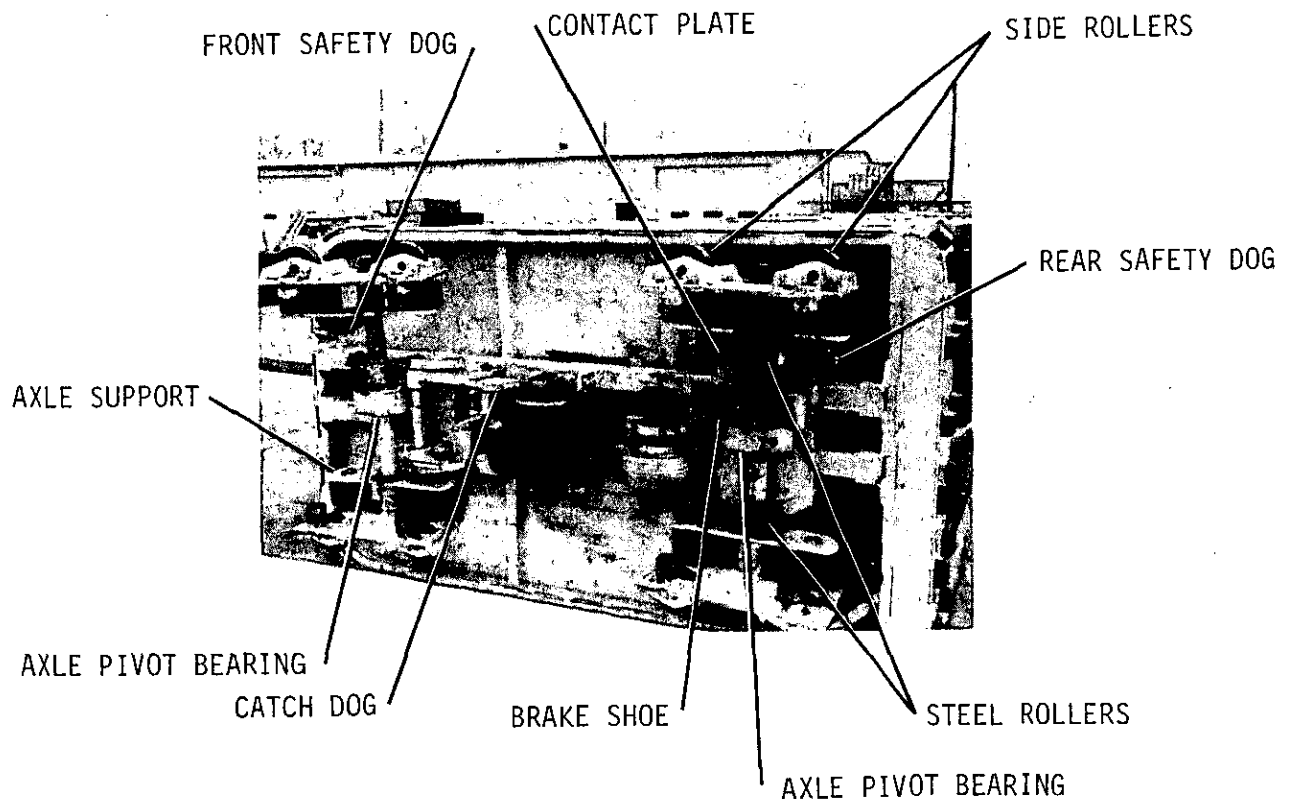

Each axle has two side rollers at each end. If these rollers become worn or loose, the axle may move to one side and not allow the catch dog to be centered in the track. Inspect side rollers for wear on the outside surface and on the inside where the bolt holds it in position. Also inspect the bolt for wear. Minimum outside diameter of roller is 3-5/8". Rollers must turn freely with no binding.

Inspect top rollers at each axle support for wear. Minimum outside diameter is 3-3/4". Rollers must turn freely with no binding.

Inspect the two steel rollers on the rear axle of each car. Hold either roller against the contact plate on the car frame and check the clearance between the other roller and contact plate. Plates must not be worn and clearance must be no more than 1/4". Rollers must turn freely with no binding.

Inspect bottom rollers at each axle support to see that they are mounted securely and turn freely with no binding.

Inspect brake shoe located on rear axle of the cars. Brake shoes must not be less than 3/8" thick at the thinnest point.

Check chain and sprockets for wear and alignment. Chain must have not more than 1/2" slack between sprockets.

Place car on straight section of track. Shake axles to check for slack in axle pivot bearings.

Center car in dipped section of track and check fluid level in fluid clutch. Fill with transmission fluid level with fill opening.

Inspect all track brake components for worn, bent or broken pins, worn mounting holes and bent or worn brake bars.

Inspect the rubber stops that restrict the upward movement of the brake bars. Rubber stops should not be cracked, torn or deteriorated.

Inspect emergency brakes on the tower spiral track by sending an empty car down the track while the emergency brakes are applied. Car must stop when it contacts the brakes.

Check the function of the emergency brake on the return track by disconnecting the air line to the air chamber. The loss of air pressure will allow the two coil springs to apply the brake. When the air line is reconnected the air pressure will cause the air chamber to compress the springs and release the brakes. Check both springs to see that they are not broken.

A limit switch located at the top of the entrance to the tower will shut off the power to the chain drive when it is contacted by a hatch which has been left open on a car. Activate the switch by flexing the "whisker" which hangs down from the switch. This will turn off power to the drive chain until the "CHAIN RESET" switch on the operators hand control box is activated.

To check the circuit which allows only one car in the tower at a time, release the brake closest to the tower and allow a car to enter the tower. Do not advance the other cars. While the car is still in the tower again try to release the brake closest to the tower. Brake should not release until the car has moved out of the tower. The circuit also has a bell which should ring as the car exits the tower.

Certification of Compliance

CHANCE MANUFACTURING COMPANY, INC.

SERVICE BULLETIN _____

We hereby certify the inspection outlined in the above-mentioned service bulletin has been performed on the _____ Amusement Ride(s), Serial No(s) _____, in accordance with the instructions and specifications supplied by Chance Manufacturing Company, Inc.

Date Bulletin Received _____

Date Inspection Performed _____

Name and Address of Person performing Inspection

Attested:

Owner _____

Maintenance Supervisor _____

Address _____

Address _____

City _____ State _____

City _____ State _____

By: _____

Date: _____

Date: _____

Results of Inspection _____

This certification must be completed and returned to Chance Manufacturing Company, Inc., within seven (7) days from receipt of the kit.



Number: B107R1061-0

Date: March 16, 1990

Supersedes: B06-0158A00

America's Largest Manufacturer of Amusement Rides

SERVICE BULLETIN

Effective Serial Numbers: ALL UNITS - Chance Manufacturing Co. Inc.

Chance Rides, Inc. SPECIFICALLY DISCLAIMS ANY LIABILITY for losses associated with rides produced by Chance Manufacturing Company, Inc.

Ride: TOBOGGAN

Subject: GENERAL INSPECTION

Service Bulletin B06-0158A00 has been superseded by this bulletin and is no longer in effect. All copies of B06-158A00 should be destroyed.

All TOBOGGAN owners are required to have the following inspections performed daily unless otherwise stated in this bulletin. These inspections must be performed by qualified personnel, capable of understanding the function of the parts and their proper installation. If there are any questions regarding the instructions or the inspections contact the Chance Customer Service Department.

NOTICE

USE ONLY THOSE COMPONENTS AUTHORIZED, SPECIFIED OR PROVIDED BY CHANCE RIDE, Inc.

CHANCE RIDES, INC. SPECIFICALLY DISCLAIMS ANY LIABILITY FOR LOSSES ASSOCIATED WITH ANY UNAUTHORIZED ALTERATIONS AND/OR MODIFICATIONS OR ADDITIONS AND INSTALLATIONS OF UNAUTHORIZED COMPONENTS.

INSPECTION PROCEDURE

- I. Inspect the two anti-roll back assemblies on each vehicle (refer to Illustration A).
1. The adjusting capscrew must be centered over the stop.
 2. The adjusting capscrew must not be bent or broken.
 3. The adjusting capscrew is held firmly against the stop by two springs.
 4. The adjusting capscrew is adjusted properly when it rests on the stop and the bottom of the anti-roll back latch is 1/8" from the bottom of the safety track.

ILLUSTRATION A

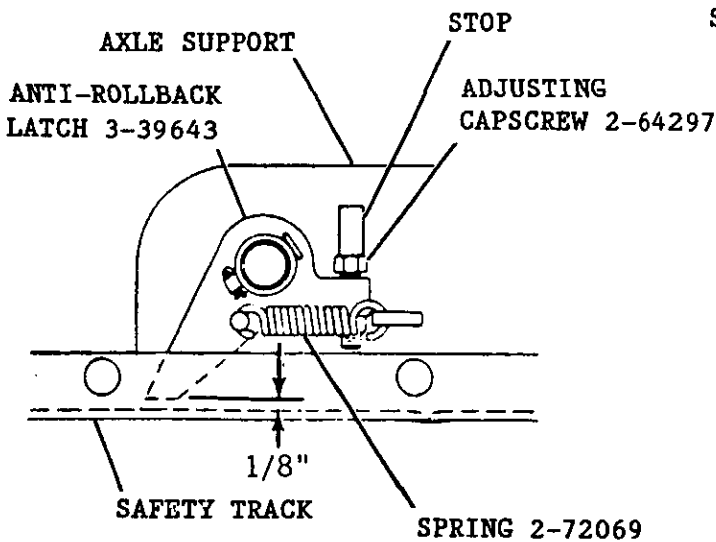

REAR ANTI-ROLLBACK ASSEMBLY

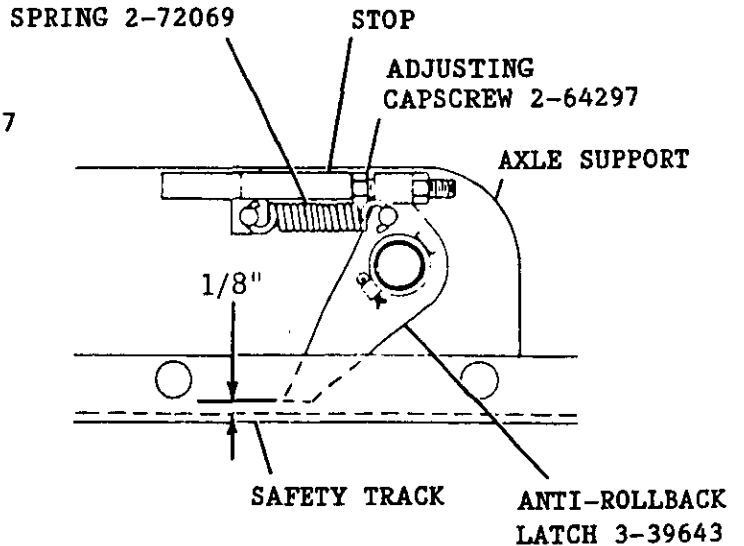

FRONT ANTI-ROLLBACK ASSEMBLY

INSPECTION PROCEDURE (Continued)

- II. Inspect all parts of the chain dog assembly (refer to Illustration B).
1. The chain dog and chain dog pickup must be mounted securely to the mounting shaft by a key and set screws.
 2. The mounting shaft must move freely allowing the chain dog to swing downward from the latched position to the extended position.
 3. The chain dog is properly adjusted when the adjusting screw stops the chain dog at a 45 degree angle.
 4. When in the latched position the chain dog must be held securely by the latch.
 5. The chain dog latch and the trip arm must be held firmly against the stop by two springs.
 6. Inspect the welds that hold the chain dog latch and the trip arm to their mounting shaft.
 7. The chain dog latch and trip arm mounting shaft must be able to turn freely.
 8. As the vehicle leaves the top of the barrel the chain dog pickup up must contact the striker plate, pushing the chain dog up into the latched position. DO NOT OPERATE THE RIDE IF THE CHAIN DOG WILL NOT LATCH IN THE UP POSITION.

ILLUSTRATION B

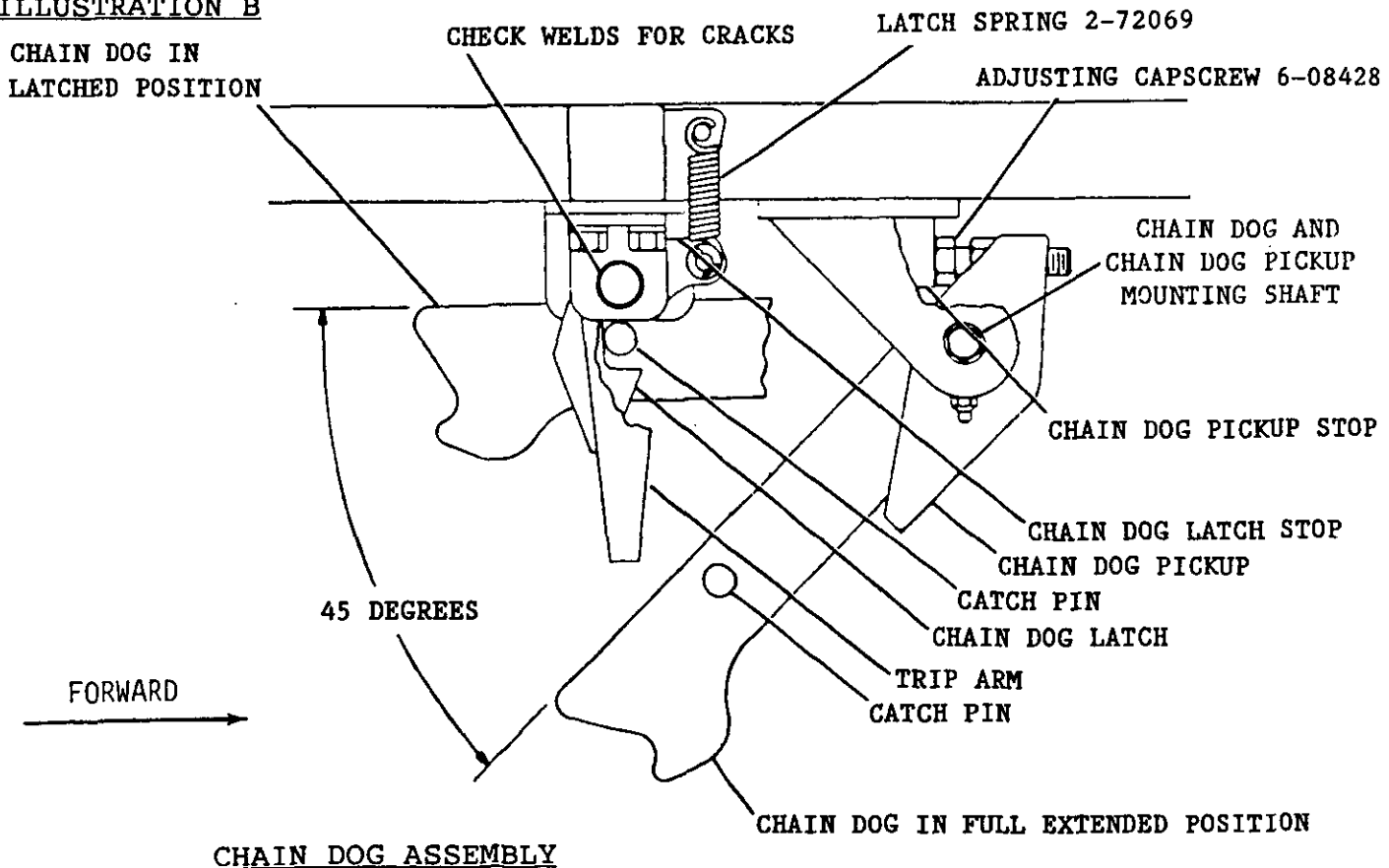

INSPECTION PROCEDURE (Continued)

- III. Inspect all top rollers, bottom cams, side rollers, and steel rollers of each vehicle (refer to Illustrations C and E).
1. Each axle has four side rollers, two at each end. If these rollers become worn or loose, the axle may move to one side and not allow the anti-roll back latch to be centered in the track. Inspect side rollers for wear, minimum outside diameter of roller must not be less than 3-1/2 inches.
 2. Side rollers must turn freely with no binding.
 3. The minimum allowable diameter of the top roller is 3-1/2 inches.
 4. The top rollers must turn freely with no binding.
 5. Bottom cam rollers must be mounted securely and turn freely with no binding.
 6. Inspect the two steel rollers on the main rear axle of each car by holding one side of the car down so that the roller is against the contact plate on the car frame, measure the clearance between the opposite roller and the contact plate. Total allowable clearance is 1/4 inch as shown in illustration E.
 7. Rollers must be able to turn freely with no binding.

ILLUSTRATION C

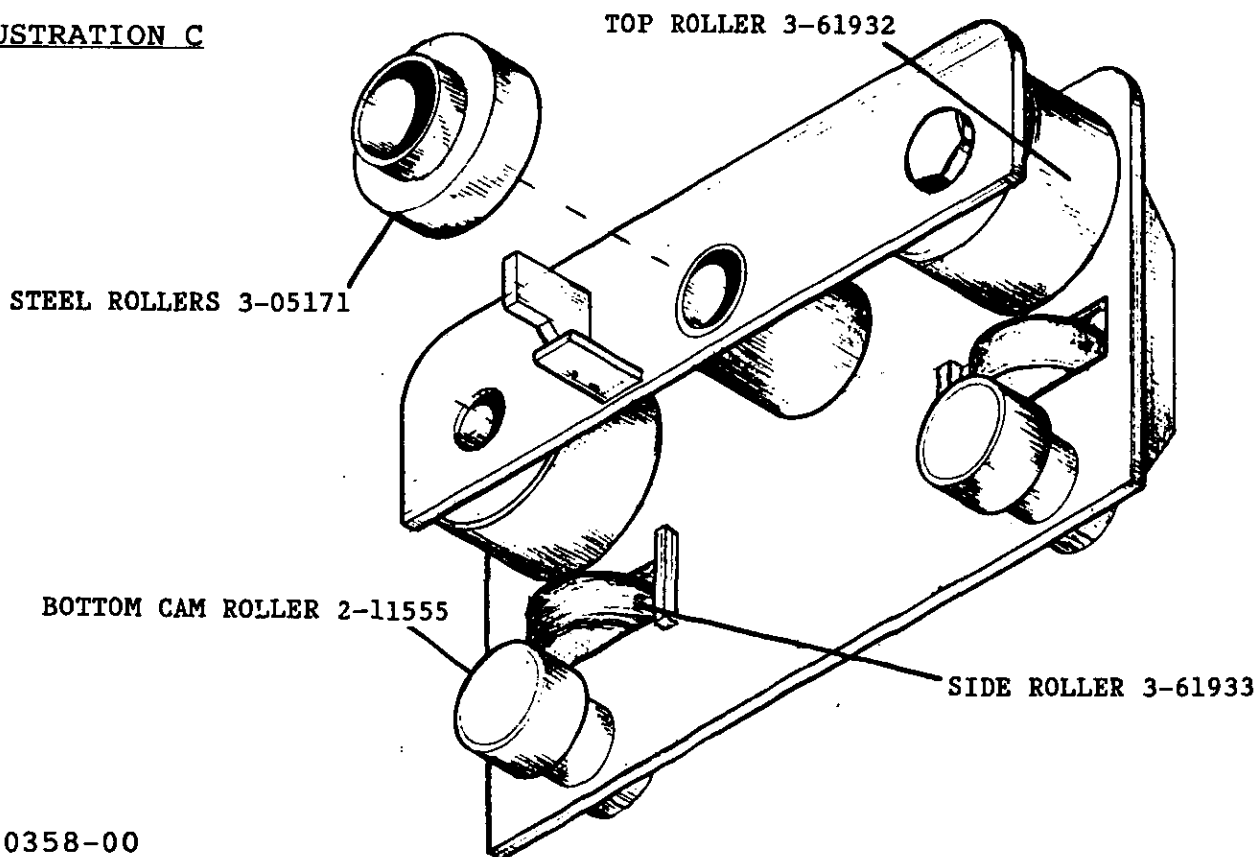

INSPECTION PROCEDURE (Continued)

- IV. Inspect hydro sheave (refer to Illustration D).
1. With a torque wrench check the torque of the 3/8 inch hexhead capscrew located on the side at the center of the hydro sheave. The torque on this capscrew must be 22 foot pounds.
 2. With the car positioned level, check the fluid in the hydro-sheave. The fluid level helps control the speed of the car. An empty car should take at least 53 seconds from the time it enters the tube until the time it is stopped in the brake section adjacent to the loading station. DO NOT OPERATE ANY CAR THAT HAS A LOW FLUID LEVEL.
 3. Inspect the chain and sprockets for wear and alignment. The chain must not have more than 1/2 inch of slack.
 4. Check air pressure of rubber tire on each car, pressure must be 50psi.

ILLUSTRATION D

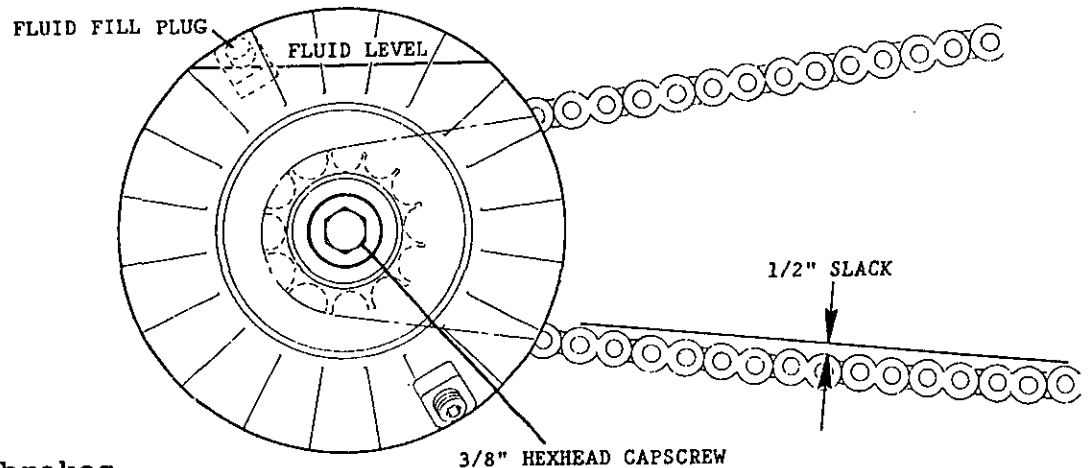

- V. Inspect brakes.
1. Inspect the brake shoe located on the rear axle of each car. Brake shoes must not be less than 3/8 inch thick at the thinnest point.
 2. Check for proper functioning of the two emergency brakes on tower spiral track by sending an empty car down the track while the emergency brakes are applied. Car must stop when it contacts the brakes.
 3. Check for proper functioning of the emergency brake on the return tract by disconnecting the air line to the air chamber. The loss of air pressure will allow the two coil springs to apply the brake. When the air line is reconnected the air pressure will cause the air chamber to compress the springs and release the brakes. Check both springs to see that they are not broken.
 4. Inspect the rubber stops that restrict the upward movement of the brake bars. Rubber stops should not be cracked, torn, or deteriorated.

INSPECTION PROCEDURE (Continued)

VI. Inspect safety blocks

1. Check the function of the limit switch at the entrance to the tower which shuts off the power to the chain drive when contacted by a car hatch which has been left open. With the chain running, activate the limit switch, the chain must stop.
2. Check the circuit which allows only one car in the tower at a time. Release the brake closest to the tower and allow a car to enter the tower. DO NOT ADVANCE THE OTHER CARS. While the first car is still in the tower try to release the brake closest to the tower again. It must not release until the car has exited from the tower. A bell at the top of the tower must ring as the car leaves the tower and moves out of this safety block.

VII. Inspect track (refer to Illustration E).

1. Inspect all track sections for wear. As track wears a flat spot develops. Any track section with a flat spot greater than one inch in width must be replaced. Any track section with a flat spot that has become concaved, regardless of its width, must be replaced.
2. Inspect all track sections for damage due to misuse or prolonged exposure to weather. Any track section that is bent from its original shape or does not line up properly with the next section of track must be replaced. Any track section that has holes in it due to rust or wear must be replaced.
3. Inspect safety track inside tower for worn or bent pins. Anti-rollback latch must be able to catch securely on all pins of the safety track.

ILLUSTRATION E

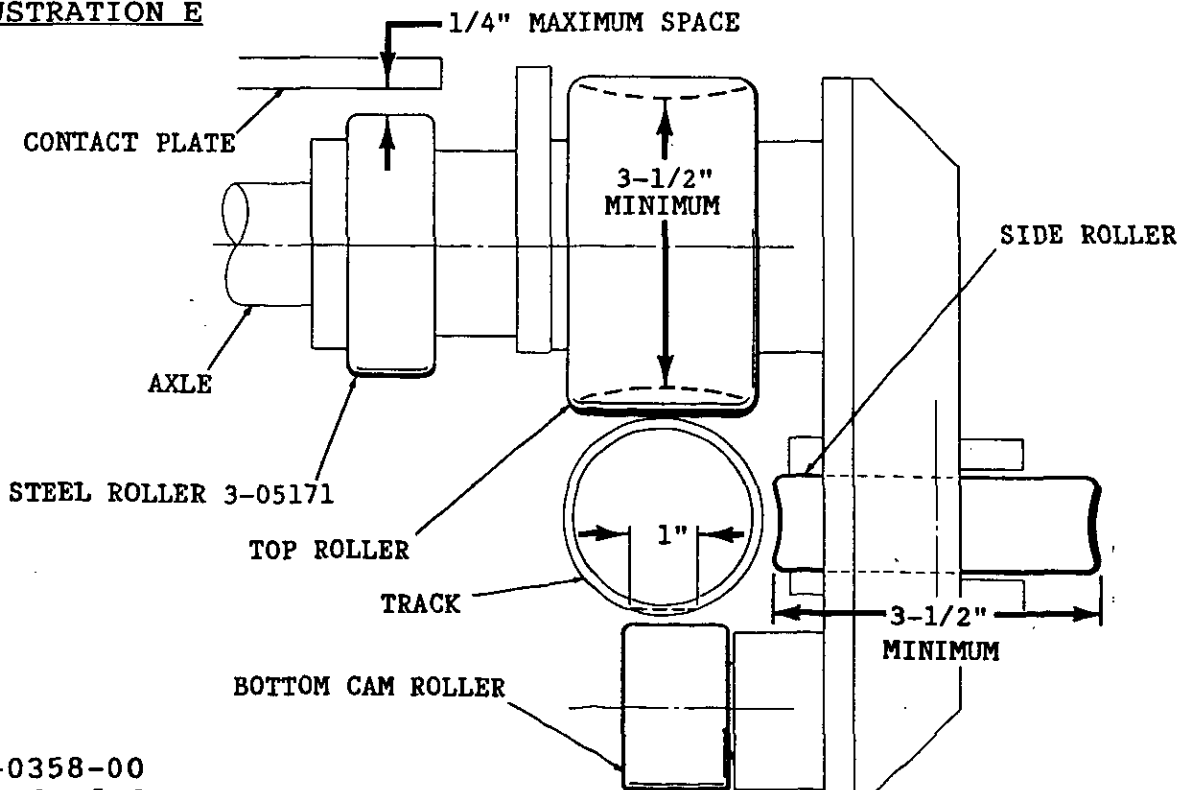



CERTIFICATION OF COMPLIANCE
FOR
SERVICE BULLETIN
B107R1061-0

We here by certify the procedure outlined in the above-mentioned service bulletin has been performed on the TOBOGGAN, Serial No(s) _____, in accordance with the instructions and specifications supplied by Chance Rides, Inc.

Date Bulletin Received _____

Date Procedure Performed _____

Name and Address of Person Performing Procedure:

Attested:

Owner _____ Maintenance Supervisor _____

Address _____ Address _____

City _____ State _____ City _____ State _____

By: _____

Date: _____ Date: _____

Results: _____

This certification must be completed and returned to CHANCE RIDES, INC.
P.O. Box 12328, WICHITA, KS 67277-2328, within fifteen (15) day of
receipt of the bulletin.