



CHANCE RIDES, INC.
4219 Irving
Wichita, KS 67277-2328
U.S.A.
Phone: 1-800-242-6231 • FAX: 1-316-942-7416
Website: www.rides.com
E-mail: rides@rides.com

Bulletin No:	B414R1245-A
Release Date:	August 31, 2000
Effective Date:	August 31, 2000
Supersedes:	N/A
Completion Date:	Immediately
Page:	1 of 5

SERVICE BULLETIN

Ride Manufacturer:	CHANCE RIDES, INC.	Affected Production Dates:	All
Ride Name:	INVERTER (Portable Model)	Affected Serial Nos.:	All units
Model No.:	414		

Abstract of Issue:
Main Drive Inspection - Daily and Weekly Inspection Points

Reason For Release:

IMPORTANT:

This service bulletin is issued to provide additional information to Safety Alert Bulletin A414R1245-0.

After performing the initial inspection described in that bulletin, the inspection procedures and intervals specified in this bulletin supersede the daily inspection required by Safety Alert Bulletin A414R1245-0.

Failure of one component in the main drive of the INVERTER can result in broken teeth on the main drive gear and/or pinions. If a broken tooth or other debris becomes lodged in the vehicle drive gears, changes to the vehicle position ("timing") can result. This can cause the vehicle to contact the trailer frame, which can result in serious injury to passengers.

Action to be Taken:

All owner/operators of the above noted INVERTER amusement rides are required to perform the daily and weekly inspections described in this service bulletin.

All work must be performed by qualified personnel, capable of understanding the function of the parts and their proper installation.

NOTICE

Use only those components authorized, specified or provided by Chance Rides, Inc.

Chance Rides, Inc. SPECIFICALLY DISCLAIMS ANY LIABILITY for losses associated with any unauthorized alterations and/or modifications or additions and installations of unauthorized components.



CHANCE RIDES, INC.
4219 Irving
Wichita, KS 67277-2328
U.S.A.
Phone: 1-800-242-6231 • FAX: 1-316-942-7416
Website: www.rides.com
E-mail: rides@rides.com

Bulletin No:	B414R1245-A
Release Date:	August 31, 2000
Effective Date:	August 31, 2000
Supersedes:	N/A
Completion Date:	Immediately
Page:	2 of 5

Ride Manufacturer: CHANCE RIDES, INC. Affected Production Dates: All

Ride Name: INVERTER (Portable Model) Affected Serial Nos.: All units

Model No.: 414

Detail of Issue:

Inspection Instructions

Inspect the main drive gear and pinion as described in the following procedures. These inspection procedures must be performed DAILY or WEEKLY, as specified.

If any abnormal conditions are found contact the Chance Customer Service Department immediately. DO NOT OPERATE THE RIDE UNTIL CORRECTIVE MEASURES ARE TAKEN.

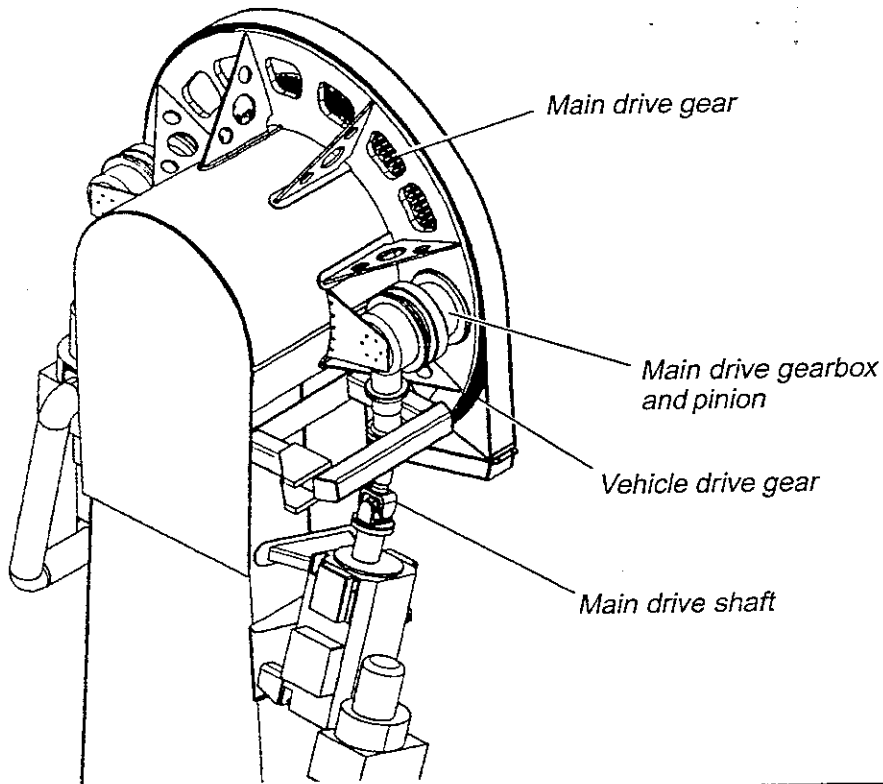

WARNING: Moving parts can cut or crush. Do not run the ride while performing the main drive gear inspection. Unless specifically instructed, do not manually move the main arm. Serious injury can result.



CHANCE RIDES, INC.
4219 Irving
Wichita, KS 67277-2328
U.S.A.
Phone: 1-800-242-6231 • FAX: 1-316-942-7416
Website: www.rides.com
E-mail: rides@rides.com

Bulletin No:	B414R1245-A
Release Date:	August 31, 2000
Effective Date:	August 31, 2000
Supersedes:	N/A
Completion Date:	Immediately
Page:	3 of 5

Ride Manufacturer: CHANCE RIDES, INC. Affected Production Dates: All

Ride Name: INVERTER (Portable Model) Affected Serial Nos.: All units

Model No.: 414

Detail of Issue (continued):

- DAILY** - Check the backlash between the main drive pinion and main drive gear as follows:
 - With the parking brake disengaged, turn one of the main drive shafts by hand until it stops.
 - Turn the drive shaft the other direction by hand, noting how far the drive shaft rotates before it stops. The drive shaft must not rotate more than 30° (one-twelfth turn).
 - Repeat the process on the other side to check the backlash at the other drive pinion.

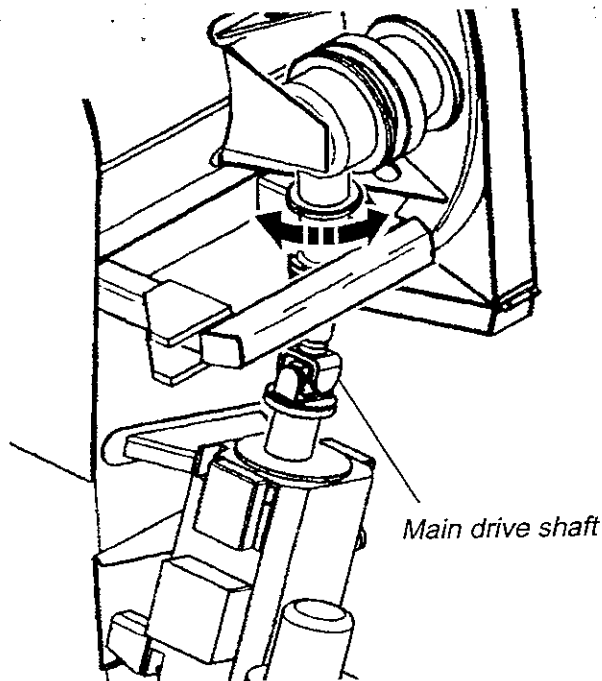

**30° maximum rotation
of main drive shafts**

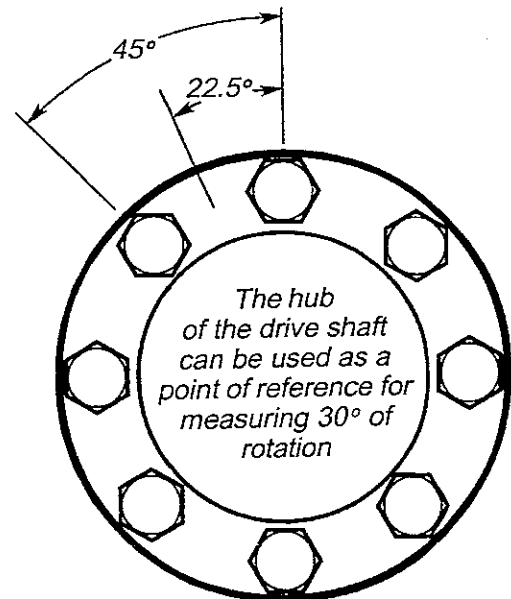



CHANCE RIDES, INC.
4219 Irving
Wichita, KS 67277-2328
U.S.A.
Phone: 1-800-242-6231 • FAX: 1-316-942-7416
Website: www.rides.com
E-mail: rides@rides.com

Bulletin No:	B414R1245-A
Release Date:	August 31, 2000
Effective Date:	August 31, 2000
Supersedes:	N/A
Completion Date:	Immediately
Page:	4 of 5

Ride Manufacturer: CHANCE RIDES, INC. Affected Production Dates: All

Ride Name: INVERTER (Portable Model) Affected Serial Nos.: All units

Model No.: 414

Detail of Issue (continued):

- DAILY** - Keeping hands and fingers clear of all moving parts, observe the pinions and main drive gear while an assistant manually moves the main arm back and forth slightly. This can be done by standing on one end of the vehicle and "bouncing" it, then doing the same thing at the other end of the vehicle.

Observe the movement of the main drive pinions in relation to the main drive gear. The pinions must only rotate. Any movement away from the main gear indicates a problem in the gearbox.

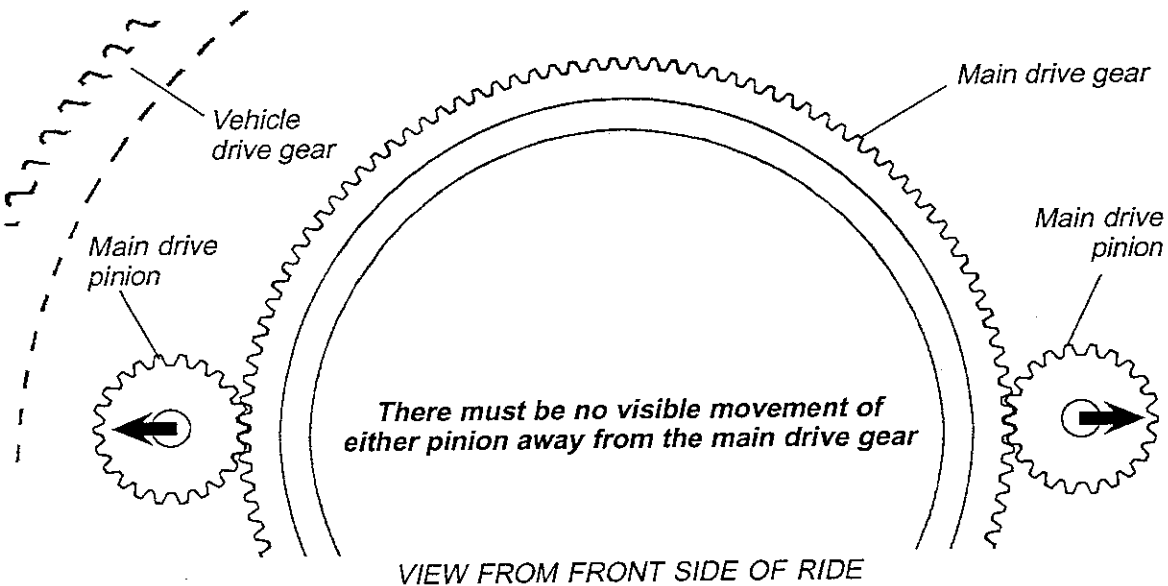

- DAILY** - Inspect both main drive gearboxes and all four vehicle drive gearboxes. If any gearbox exhibits oil leakage or excessively noisy operation, it is likely that failure of that gearbox has occurred



CHANCE RIDES, INC.
4219 Irving
Wichita, KS 67277-2328
U.S.A.
Phone: 1-800-242-6231 • FAX: 1-316-942-7416
Website: www.rides.com
E-mail: rides@rides.com

Bulletin No:	B414R1245-A
Release Date:	August 31, 2000
Effective Date:	August 31, 2000
Supersedes:	N/A
Completion Date:	Immediately
Page:	5 of 5

Ride Manufacturer: CHANCE RIDES, INC. Affected Production Dates: All

Ride Name: INVERTER (Portable Model) Affected Serial Nos.: All units

Model No.: 414

Detail of Issue (continued):

- WEEKLY** - Carefully inspect the teeth on the main drive gear. Look for broken, chipped or cracked gear teeth. If necessary, wipe away the grease to see the teeth clearly. The gear is accessible for inspection through holes in the structure and in the gear guard. If necessary, remove the gear guard.

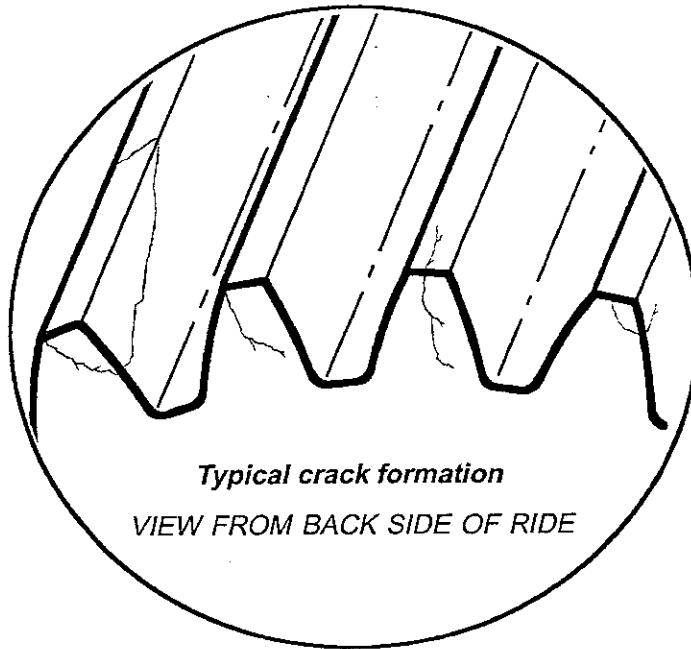

Typical crack formation
VIEW FROM BACK SIDE OF RIDE