



CHANCE RIDES, INC.
4219 Irving
Wichita, KS 67277-2328
U.S.A.
Phone: 1-800-242-6231 • FAX: 1-316-942-7416
Website: www.rides.com
E-mail: rides@rides.com

Bulletin No:	B414R1218-0
Release Date:	June 30, 1999
Effective Date:	August 30, 1999
Supersedes:	N/A
Completion Date:	August 30, 1999
Page:	1 of 3

SERVICE BULLETIN

Ride Manufacturer: CHANCE RIDES, INC. Affected Production Dates: All

Ride Name: INVERTER (Portable Model) Affected Serial Nos.: All units
 INVERTER (Park Model)
 DOUBLE INVERTER

Model No.: 414

Abstract of Issue:
Step Valve Cover

Reason For Release:

Chance Rides, Inc. has become aware that the step valve on the INVERTER amusement ride can be accidentally actuated by the operator or passengers as they are loaded and unloaded, causing the step to raise. Unexpected movement of the step can cause injury to persons in its path.

Action to be Taken:

Chance Rides, Inc. has developed a cover which requires deliberate action by the operator to actuate the step valve. All owner/operators of the above noted INVERTER amusement rides are required to install the Step Valve Cover Kit, part number K414R1218-0, using the instructions on the following page of this bulletin. The kit includes all parts necessary to rework one vehicle. For DOUBLE INVERTER rides, order two kits.

The parts will be provided at no charge if ordered within 30 days of the release date of this bulletin.

All work must be performed by qualified personnel, capable of understanding the function of the parts and their proper installation.

NOTICE

Use only those components authorized, specified or provided by Chance Rides, Inc.

Chance Rides, Inc. **SPECIFICALLY DISCLAIMS ANY LIABILITY** for losses associated with any unauthorized alterations and/or modifications or additions and installations of unauthorized components.



CHANCE RIDES, INC.
4219 Irving
Wichita, KS 67277-2328
U.S.A.
Phone: 1-800-242-6231 • FAX: 1-316-942-7416
Website: www.rides.com
E-mail: rides@rides.com

Bulletin No: B414R1218-0
Release Date: June 30, 1999
Effective Date: August 30, 1999
Supersedes: N/A
Completion Date: August 30, 1999
Page: 2 of 3

Ride Manufacturer: CHANCE RIDES, INC. Affected Production Dates: All

Ride Name: INVERTER (Portable Model) Affected Serial Nos.: All Units
INVERTER (Park Model)
DOUBLE INVERTER

Model No.: 414

Detail of Issue (continued):

Kit number K414R1218-0 contains the following:

<u>Part Number</u>	<u>Component</u>	<u>Quantity</u>
414-0118-030	COVER - STEP VALVE	1
66149000	RIVET - AD612BS (3/16")	4

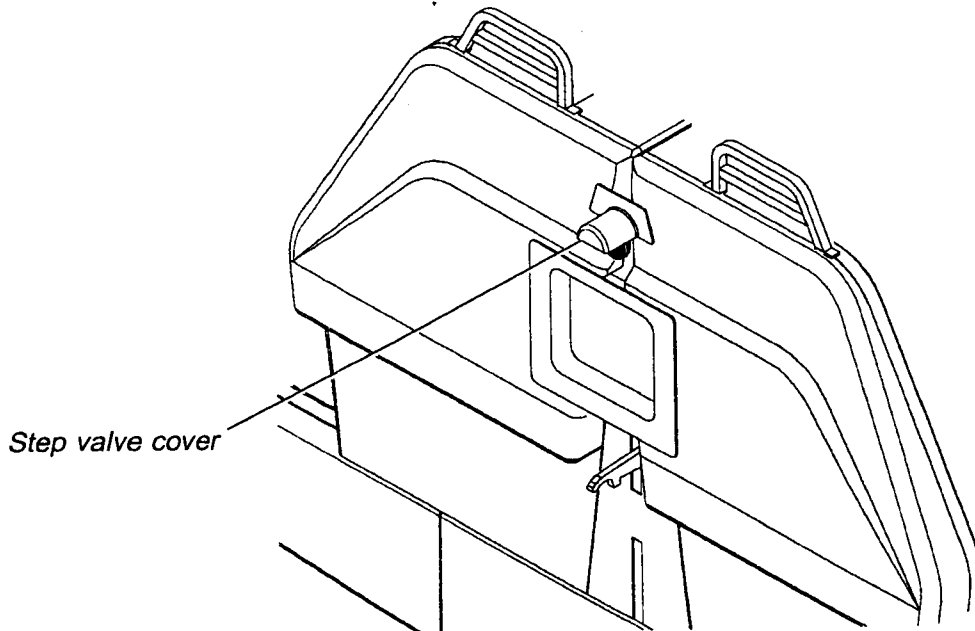

Installation Instructions - Step Valve Cover

1. Locate the cover so that it is centered over the step valve knob.
2. Drill through the cover and the fiberglass panels using a 3/16" drill. Maintain 3/8" margin on all edges.
3. Secure the cover to the vehicle using the four pop rivets provided.



CHANCE RIDES, INC.
4219 Irving
Wichita, KS 67277-2328
U.S.A.
Phone: 1-800-242-6231 • FAX: 1-316-942-7416
Website: www.rides.com
E-mail: rides@rides.com

Bulletin No:	B414R1218-0
Release Date:	June 30, 1999
Effective Date:	August 30, 1999
Supersedes:	N/A
Completion Date:	August 30, 1999
Page:	3 of 3

Ride Manufacturer: CHANCE RIDES, INC. Affected Production Dates: All

Ride Name: INVERTER (Portable Model) Affected Serial Nos.: All Units
 INVERTER (Park Model)
 DOUBLE INVERTER

Model No.: 414

Detail of Issue (continued):

*Center cover over
step valve knob*

*Drill 3/16" diameter
holes and install pop
rivets provided
(4 places)*

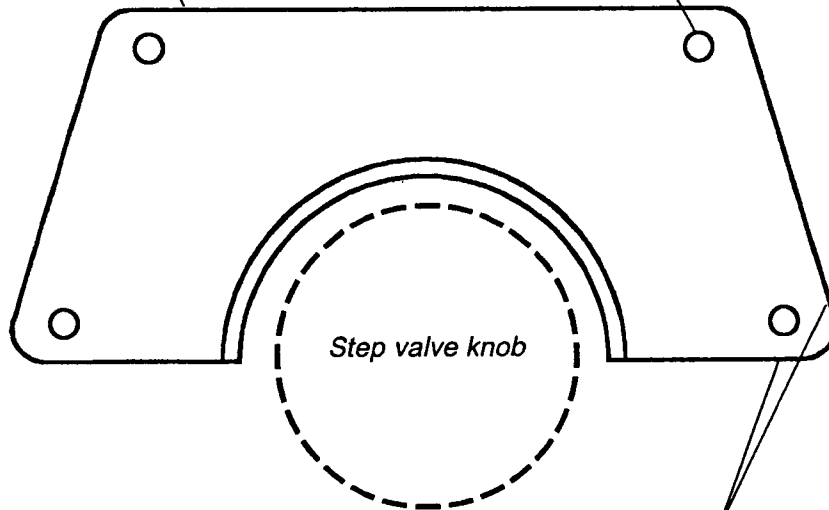

Step valve knob

*Locate holes centers to
maintain 3/8" margin on
all edges*