



CHANCE RIDES MANUFACTURING, INC.
4200 Walker
Wichita, KS 67277-2328
U.S.A.
Phone: 1-316-942-7411 • FAX: 1-316-942-2012
Website: www.rides.com
E-mail: rides@rides.com

Bulletin No:	B391CRM119-0
Release Date:	July 18, 2003
Effective Date:	Immediately
Supersedes:	N/A
Completion Date:	Immediately
Page:	1 of 2

SERVICE BULLETIN

Ride Manufacturer: CHANCE RIDES, INC.
CHANCE MANUFACTURING CO., INC.

Affected Production Dates: All

Ride Name: FALLING STAR

Affected Serial Nos.: All Units

Model No.: 391

Abstract of Issue:
Sweep Arm Inspection

Reason For Release:

Chance Rides Manufacturing, Inc. has become aware of cracks in the sweep arm of at least one FALLING STAR amusement ride. Failure of a sweep arm could result in serious injury to passengers and/or bystanders.

Action to be Taken:

Chance Rides Manufacturing, Inc. requires all owner/operators of the above noted FALLING STAR amusement rides to cease operation of the ride until the inspection described in this bulletin is performed. If any indications are found, contact the Customer Service Department at Chance Rides Manufacturing, Inc. immediately for instructions on further action to be taken.

DO NOT ATTEMPT TO WELD OR OTHERWISE REPAIR THE SWEEP ARMS EXCEPT AS SPECIFICALLY INSTRUCTED BY CHANCE RIDES MANUFACTURING, INC.

If no indications are found, operation of the ride can resume. However, both the front and rear sweep arms must be inspected as described ANNUALLY.

All work must be performed by qualified personnel, capable of understanding the function of the parts and their proper installation. Use only those components authorized, specified or provided by Chance Rides Manufacturing, Inc. All applicable OSHA safety standards and safe industry practices must be observed.

Observe all safety information contained in the manufacturer's manuals. Make available this bulletin and all related technical information to personnel using the equipment.

Chance Rides Manufacturing, Inc. issues notifications for the benefit of owners of amusement rides manufactured by Chance Rides Manufacturing, Inc. As a service to the industry, and in the interest of employee and public safety, Chance Rides Manufacturing, Inc. also issues notifications for the benefit of owners of amusement ride equipment for which the manufacturer no longer exists, such as the Allan Herschell Company, Chance Manufacturing Co., Inc., Chance Rides, Inc., etc. In doing so, Chance Rides Manufacturing, Inc. does not assume liability for losses associated with amusement ride equipment built by manufacturers other than Chance Rides Manufacturing, Inc.



CHANCE RIDES MANUFACTURING, INC.
4200 Walker
Wichita, KS 67277-2328
U.S.A.
Phone: 1-316-942-7411 • FAX: 1-316-942-2012
Website: www.rides.com
E-mail: rides@rides.com

Bulletin No:	B391CRM119-0
Release Date:	July 18, 2003
Effective Date:	Immediately
Supersedes:	N/A
Completion Date:	Immediately
Page:	2 of 2

Ride Manufacturer: CHANCE RIDES, INC.
CHANCE MANUFACTURING CO., INC.

Affected Production Dates: All

Ride Name: FALLING STAR

Affected Serial Nos.: All Units

Model No.: 391

Detail of Issue

Sweep Arm Inspection Procedure

Visually inspect both the front and rear sweep arms, paying particular attention to the areas indicated in the following illustration. Look for indications in the steel angles at all four corners, and check the welded joints for indications in the welds and the parent metal. If any indication is found, **DONOT OPERATE THE RIDE**. Contact the Customer Service Department at Chance Rides Manufacturing, Inc. for specific instructions on further action to be taken. This is an annual inspection.

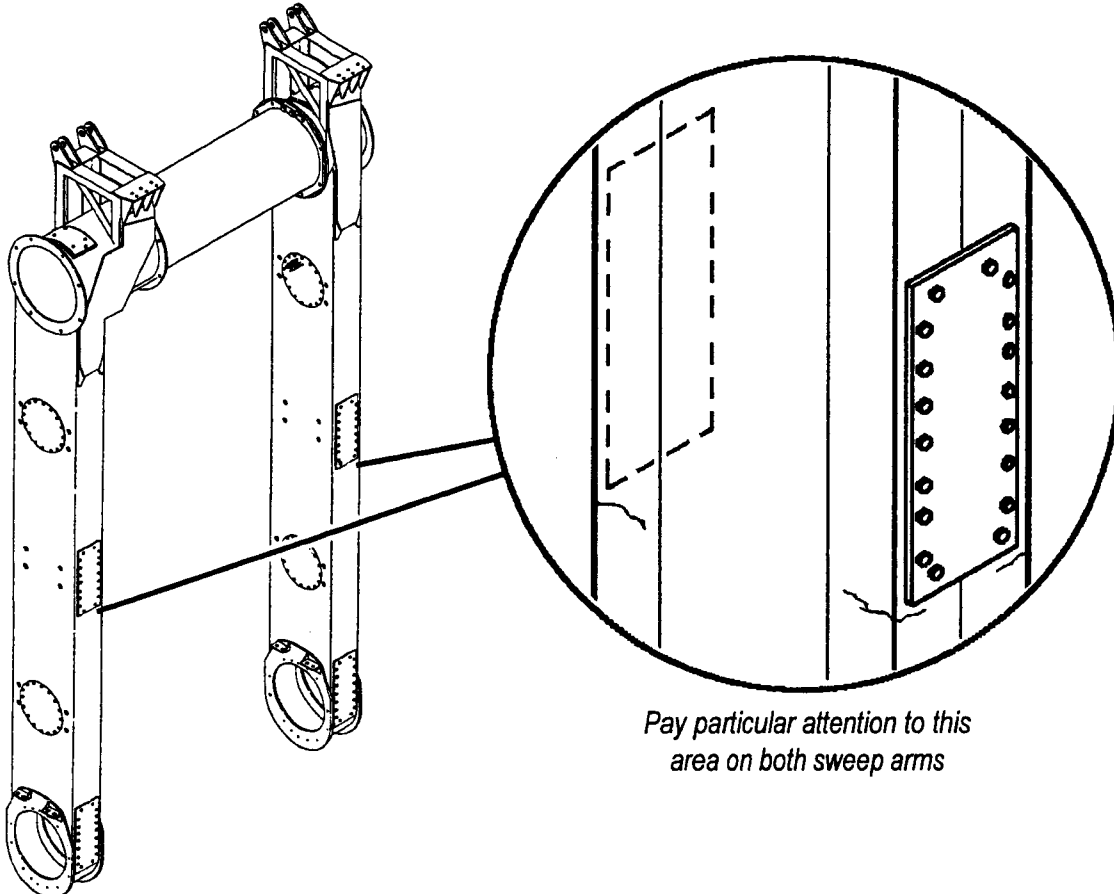

Pay particular attention to this area on both sweep arms