



**CHANCE RIDES MANUFACTURING, INC.**  
**4200 Walker**  
**Wichita, KS 67277-2328**  
**U.S.A.**  
**Phone: 1-316-942-7411 • FAX: 1-316-942-2012**  
**Website: www.rides.com**  
**E-mail: rides@rides.com**

Bulletin No: B408CRM104-0  
 Release Date: November 6, 2002  
 Effective Date: November 6, 2002  
 Supersedes: B408R1210-0  
 Completion Date: N/A  
 Page: 1 of 6

# SERVICE BULLETIN

Ride Manufacturer: CHANCE RIDES, INC.      Affected Production Dates: 1/31/96 through 8/1/98

Ride Name: CHAOS      Affected Serial Nos.: 408-00196 and  
 408-02097 through 408-03998

Model No.: 408

Abstract of Issue:  
 Inspection, Replacement and Operation of Hydraulic Lock Cylinders

Reason For Release:  
**Chance Rides, Inc. service bulletin B408R1210-0 is superseded by this bulletin and is no longer in effect.**

The passenger restraint system on the above noted CHAOS amusement rides incorporates three hydraulic lock cylinders on each vehicle - one for each lap bar and one for the secondary restraint bar. In the event a hydraulic lock cylinder fails, a redundant mechanical lock prevents the restraint bar from opening.

The manufacturer of the hydraulic lock cylinder has made design changes over the years to provide better performance and longer service life. With one exception, all versions of this component are acceptable for use on the ride in the locations described on the following pages of this bulletin. A manufacturing defect was discovered in one version. Chance Rides, Inc. service bulletin B408R1210-0 required these cylinders to be removed from service no later than September 18, 1999.

This bulletin provides detailed identification of all versions of the hydraulic locking cylinder and the location where each version can be used.

Action to be Taken:  
 All owners of the above noted amusement rides are required to inspect all hydraulic lock cylinders and the locations where they are installed per the instructions on the following pages of this bulletin. Order and install part number 22162104 in the appropriate quantity to replace any cylinder which does not meet the specifications provided.

All work must be performed by qualified personnel, capable of understanding the function of the parts and their proper installation. Use only those components authorized, specified or provided by Chance Rides Manufacturing, Inc. All applicable OSHA safety standards and safe industry practices must be observed.

Observe all safety information contained in the manufacturer's manuals. Make available this bulletin and all related technical information to personnel using the equipment.



**CHANCE RIDES MANUFACTURING, INC.**  
4200 Walker  
Wichita, KS 67277-2328  
U.S.A.  
Phone: 1-316-942-7411 • FAX: 1-316-942-2012  
Website: [www.rides.com](http://www.rides.com)  
E-mail: [rides@rides.com](mailto:rides@rides.com)

Bulletin No:	B408CRM104-0
Release Date:	November 6, 2002
Effective Date:	November 6, 2002
Supersedes:	B408R1210-0
Completion Date:	N/A
Page:	5 of 6

Ride Manufacturer: CHANCE RIDES, INC. Affected Production Dates: 1/31/96 through 8/1/98

Ride Name: CHAOS Affected Serial Nos.: 408-00196 and 408-02097 through 408-03998

Model No.: 408

Detail of Issue (continued):

### Monthly Inspection of Hydraulic Lock Cylinders

The passenger restraint system on each vehicle incorporates three hydraulic lock cylinders - one for each lap bar and one for the secondary restraint bar. Remove the back cover from the vehicle to gain access to the lock cylinders.

Perform the following inspection on the lock cylinders monthly or at every set-up, whichever occurs first. Check all three lock cylinders on EVERY VEHICLE.

1. Visually inspect each lock cylinder for oil leakage around the seals.
2. Inspect for any signs of external damage, including the spherical bearings in the rod end.
3. Activate the solenoid and check for smooth movement of the piston rod in extension and compression.
4. Inspect the piston rod for any evidence of damage. **DO NOT PUT CLAMP PRESSURE ON THE PISTON ROD.**
5. Inspect the accumulator hose and hose fittings for leakage.
6. Inspect the solenoid valve for damage.
7. Inspect the accumulator clamp nuts to ensure the nuts are tight and have not loosened.

If any sign of damage, leakage or other malfunction is noted, **REPLACE THE LOCK CYLINDER.**

**IMPORTANT:** *Passenger restraint lock cylinders are not repairable in the field. If a damaged or malfunctioning lock cylinder is found, replace it with a new or re-manufactured part, available from CHANCE RIDES MANUFACTURING, INC. DO NOT ATTEMPT TO REPAIR THE CYLINDER.*



**WARNING:** The passenger restraint lock cylinder is under high pressure. **DO NOT ATTEMPT TO DISASSEMBLE** the cylinder or serious personal injury can result. Replace the cylinder with a new or re-manufactured part.



**CHANCE RIDES MANUFACTURING, INC.**

4200 Walker  
Wichita, KS 67277-2328  
U.S.A.

Phone: 1-316-942-7411 • FAX: 1-316-942-2012

Website: [www.rides.com](http://www.rides.com)

E-mail: [rides@rides.com](mailto:rides@rides.com)

Bulletin No: B408CRM104-0

Release Date: November 6, 2002

Effective Date: November 6, 2002

Supersedes: B408R1210-0

Completion Date: N/A

Page: 4 of 6

Ride Manufacturer: CHANCE RIDES, INC.

Affected Production Dates: 1/31/96 through 8/1/98

Ride Name: CHAOS

Affected Serial Nos.: 408-00196 and  
408-02097 through 408-03998

Model No.: 408

Detail of Issue (continued):

**Operation - Manually Releasing Passenger Restraints**

Use the following information in conjunction with the procedure in the *CHAOS Operation Manual*.

*To manually release the LAP BAR on this side of the vehicle:*

- Raise the release lever (top access hole).
- While holding the release lever up, pull the red release plunger or push the black release button (lower access hole)

*To manually release the LAP BAR on this side of the vehicle:*

- Raise the release lever (top access hole).
- While holding the release lever up, pull the red release plunger or push the black release button (lower access hole)

*To manually release the SECONDARY RESTRAINT BAR:*

- Raise the release lever (top access hole).
- While holding the release lever up, pull the red release plunger or push the black release button (lower access hole)

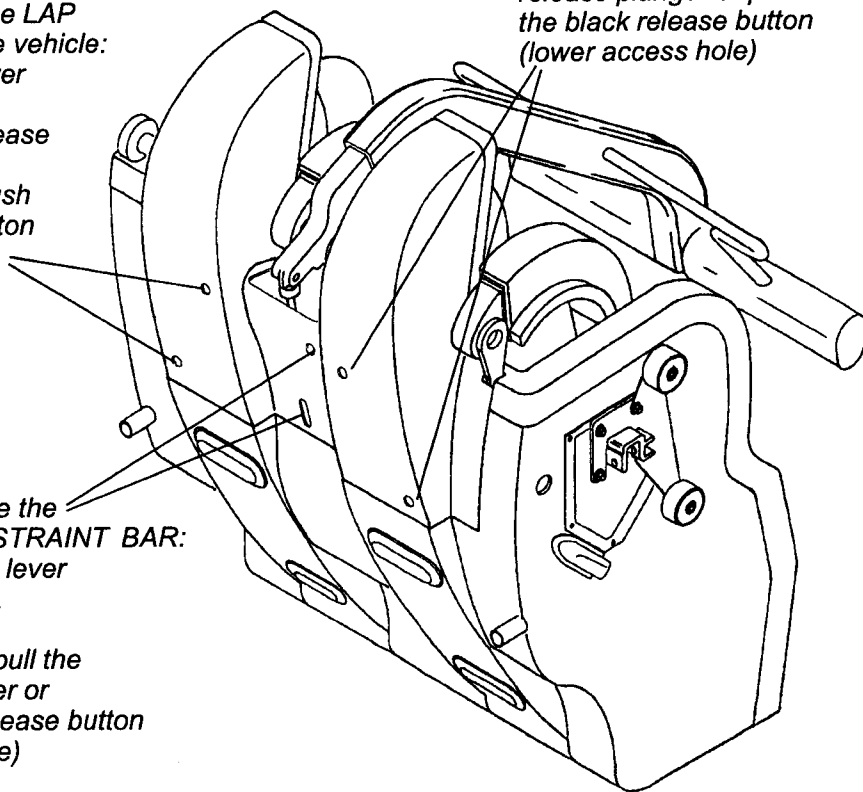



**CHANCE RIDES MANUFACTURING, INC.**  
 4200 Walker  
 Wichita, KS 67277-2328  
 U.S.A.  
 Phone: 1-316-942-7411 • FAX: 1-316-942-2012  
 Website: [www.rides.com](http://www.rides.com)  
 E-mail: [rides@rides.com](mailto:rides@rides.com)

Bulletin No:	B408CRM104-0
Release Date:	November 6, 2002
Effective Date:	November 6, 2002
Supersedes:	B408R1210-0
Completion Date:	N/A
Page:	3 of 6

Ride Manufacturer: CHANCE RIDES, INC.

Affected Production Dates: 1/31/96 through 8/1/98

Ride Name: CHAOS

Affected Serial Nos.: 408-00196 and  
 408-02097 through 408-03998

Model No.: 408

Detail of Issue (continued):

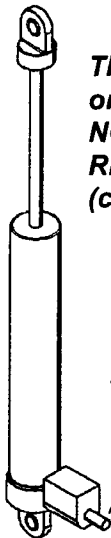

*This cylinder can be used on the lap bars, but **NOT THE SECONDARY RESTRAINT BARS** (center position)*

Red release plunger

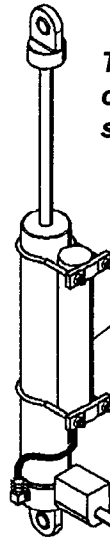

*This cylinder can be used on the lap bars and the secondary restraint bars*

Accumulator

Red release plunger

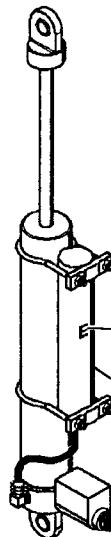

*This cylinder can be used on the lap bars and the secondary restraint bars. It **MUST HAVE THE STAMPED LETTER** as shown.*

**DO NOT USE THIS CYLINDER IF IT DOES NOT HAVE THE STAMPED LETTER.** Replace it with the correct cylinder.

Letter "E" stamped on accumulator

Accumulator with hose coming out of **BOTTOM**

Black release button

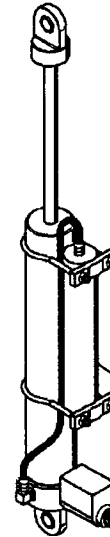

*This cylinder can be used on the lap bars and the secondary restraint bars.*

**Note the hose coming out of the top of the accumulator.**

Accumulator with hose coming out of **TOP**

Black release button



**CHANCE RIDES MANUFACTURING, INC.**  
4200 Walker  
Wichita, KS 67277-2328  
U.S.A.  
Phone: 1-316-942-7411 • FAX: 1-316-942-2012  
Website: [www.rides.com](http://www.rides.com)  
E-mail: [rides@rides.com](mailto:rides@rides.com)

Bulletin No:	B408CRM104-0
Release Date:	November 6, 2002
Effective Date:	November 6, 2002
Supersedes:	B408R1210-0
Completion Date:	N/A
Page:	2 of 6

Ride Manufacturer: CHANCE RIDES, INC.

Affected Production Dates: 1/31/96 through 8/1/98

Ride Name: CHAOS

Affected Serial Nos.: 408-00196 and  
408-02097 through 408-03998

Model No.: 408

Detail of Issue

### Inspection Procedure

Inspect the three hydraulic lock cylinders on all vehicles (54 total). Identify the cylinders based on the distinguishing characteristics detailed on the next page.

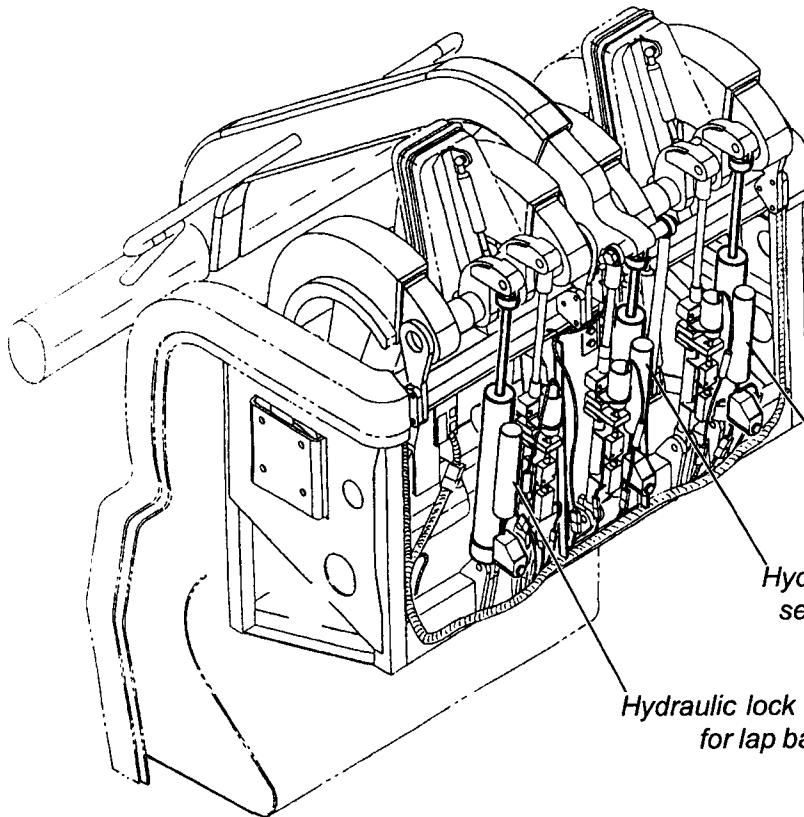

**IMPORTANT:**  
Note the location at which each cylinder is installed. Pay particular attention to the cylinder for the secondary restraint bar (center position).

Hydraulic lock cylinder for lap bar

Hydraulic lock cylinder for secondary restraint bar

Hydraulic lock cylinder for lap bar



**CHANCE RIDES MANUFACTURING, INC.**

**4200 Walker  
Wichita, KS 67277-2328  
U.S.A.**

**Phone: 1-316-942-7411 • FAX: 1-316-942-2012**

**Website: [www.rides.com](http://www.rides.com)**

**E-mail: [rides@rides.com](mailto:rides@rides.com)**

Bulletin No: B408CRM104-0

Release Date: November 6, 2002

Effective Date: November 6, 2002

Supersedes: B408R1210-0

Completion Date: N/A

Page: 6 of 6

Ride Manufacturer: CHANCE RIDES, INC.

Affected Production Dates: 1/31/96 through 8/1/98

Ride Name: CHAOS

Affected Serial Nos.: 408-00196 and  
408-02097 through 408-03998

Model No.: 408

Detail of Issue (continued):

#### **Storage of Hydraulic Lock Cylinders**

To obtain maximum service life from the hydraulic lock cylinders, always close the lap bars and secondary restraint bars during long periods of inactivity, such as during off-season storage of the ride.

The accumulator (if equipped) has a breather at the end opposite the hose. Do not allow precipitation to enter the breather. This will cause the unit to malfunction or become damaged. The breather should be covered during long periods of inactivity, such as during winter storage. If precipitation should enter into the breather, turn the lock cylinder over and allow the moisture to drain out. **DONOT ALLOW MOISTURE TO FREEZE INSIDE THE ACCUMULATOR**, or permanent damage to the lock cylinder can result.

Similarly, if hydraulic lock cylinders are stored separate from the ride (e.g., as spare parts), always fully extend the cylinder before storing. Cover the breather on the accumulator (if equipped) to prevent moisture from entering.

Chance Rides Manufacturing, Inc. issues notifications for the benefit of owners of amusement rides manufactured by Chance Rides Manufacturing, Inc. As a service to the industry, and in the interest of employee and public safety, Chance Rides Manufacturing, Inc. also issues notifications for the benefit of owners of amusement ride equipment for which the manufacturer no longer exists, such as the Allan Herschell Company, Chance Manufacturing Co., Inc., Chance Rides, Inc., etc. In doing so, Chance Rides Manufacturing, Inc. does not assume liability for losses associated with amusement ride equipment built by manufacturers other than Chance Rides Manufacturing, Inc.